

# THE ORINDA NEWS

Gratis  
Volume 23, Number 11

The Orinda Association, Publisher  
Delivered to 9,000 Households and Businesses in Orinda

12 Issues Annually  
November 2008

## Nominations for OA Awards Due December 1

Nominations for Volunteer of the Year and the William Penn Mott, Jr. Awards are due December 1. Forms can be downloaded at [www.orindaassociation.org](http://www.orindaassociation.org). Fax completed forms to 254-8312 or mail to P.O. Box 97, Orinda, CA 94563. The annual awards dinner takes place January 25 at the Orinda Country Club.

## Heated City Council Election

By SALLY HOGARTY  
Editor

On November 4, Orinda residents will choose between three candidates to fill two seats on the Orinda City Council. One candidate, Robert Larsen, has recently called into question campaign contributions received by the two incumbents running for re-election.

"I don't know whether it is illegal or not, but taking campaign contributions from special interest groups creates the appearance of impropriety," says Larsen. "If our country is ever going to deal with campaign reform, it must start at the local level."

Larsen feels that accepting campaign contributions from groups that may have future business with the City of Orinda raises concern. "These are not inconsequential sums of money that have the potential to affect someone's vote, whether they are aware of it or not," he says.

Larsen notes that incumbent Victoria Smith has received contributions from Waste Management, Operating Engineers Local #3, and Teamsters Local 315 that might affect her judgment when a new garbage contract is negotiated. According to Smith, contributions she has received from these groups are neither illegal nor unethical. "The majority of my contributors are citizens of Orinda. I am very proud of that fact. As to the contributions I've received from Waste Management or the unions, those groups are regulated by the Contra Costa Solid Waste Authority, of which I am one of 12 board members. The fact that I am supported by both management and the workers speaks to my ability to bring consensus."

As of press time, Glazer's contributions were all from individuals, 99 percent of whom live in Orinda. He does acknowledge that he received contributions from four businesses in addition to individuals; during his 2004 campaign. According to Glazer's 2004 form 460 (campaign finance statements required by law), those four businesses included a Sacramento political consulting firm, a resort developer, a California real estate political group, and an investment company.

Larsen's contributors are all individuals; the majority are involved in healthcare and live in the greater Bay Area. Four contributors are from Southern California and four are from out-of-state.

For a complete list of each candidate's contributors, call City Clerk Michele Olsen at 254-4221 and ask for the candidates' 460 forms. A list of endorsements for Victoria Smith is also available on her website at [www.voteformichelle.com](http://www.voteformichelle.com).

## City Council Candidates List Priorities (see pg 6-9)



Steve Glazer

CONTRIBUTED PHOTO



Victoria Smith

CONTRIBUTED PHOTO

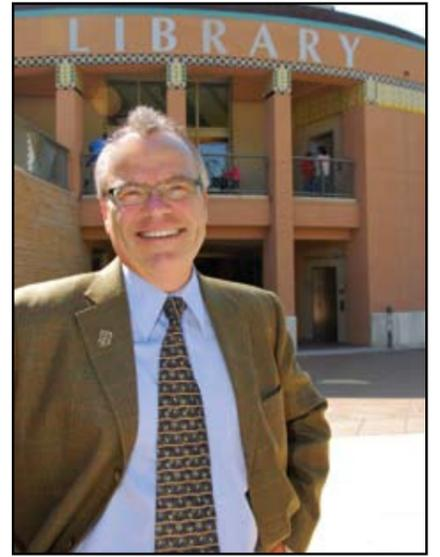

Bob Larsen

CONTRIBUTED PHOTO

## Acalanes School District Parcel Tax on November Ballot

By CHRIS LAVIN  
Assistant Editor

Even though California's budget has passed, schools are still in trouble, and proponents of the measure that the Acalanes Union High School District has placed on the ballot say approval will make a difference in the conditions of facilities at our local schools. The district has placed a \$93 million bond on the November 4 ballot, Measure E, and if passed, will go toward upgrading and repairing school facilities, and includes a 10-year, \$6 million technology replacement fund.

The Acalanes district serves four high schools in Orinda, Lafayette, Moraga and portions of Walnut Creek. No difference in current property tax bills is expected, although the last tax assessment included an exemption for senior citizens, who will not get an exemption if this measure passes.

The cost of the bond will be \$30 per \$100,000 of a home's assessed value – not its market value. It is the current rate that homeowners are already paying for bonds that were approved in 2002. By extending the period in which the bond will be repaid,

proponents say that today's lower interest rates will ensure that the current line item on property tax bills will not increase.

If approved, Measure E will net Orinda's Miramonte High School roughly \$12 million in upgrades, earmarked for infrastructure, repairs to hillside slides, athletic field maintenance, heating, ventilation and air-conditioning. "The tools we use in classrooms today weren't imaged when our schools were built," said Vanessa Crews, an Acalanes district board member, about the technology improvements. She said the schools were built between 1945 and 1961, when technology upgrades were not part of foreseen improvements. "Technology and upgrading our schools' capacity to support the computers and equipment that are commonplace in schools and businesses today is a major factor in this bond measure,"

she said.

At Miramonte, the bond would replace water mains, worn mechanical equipment, and more. A list of projects that would be funded by Measure E can be found at [www.AboutMeasureE.org](http://www.AboutMeasureE.org). Fifty-five percent approval is required for passage.

Opponents say that the Acalanes district already has three bond measures on which they are collecting money through property taxes, and say this is another one. Their ballot argument also states that "aging roofs" should not be paid for by a bond, but by general funds. Both arguments can be seen by visiting [www.smartvoter.org](http://www.smartvoter.org). Richard Colman of Orinda objects to the measure because there is no senior citizen exemption and would like to see promises from the district of higher student grades and higher property tax values.

## OCCA's 29th Annual Holiday Bazaar Takes Place November 1 and 2



SALLY HOGARTY

The Orinda Community Center Auxiliary promises lots of great gift ideas as more than 80 vendors display unique creations at the Orinda Community Center. Carolers, magicians, and holiday music will add to the festive event. Child art classes are available for children while parents shop. For more information, call 254-2445.

### IN THIS ISSUE

	Page
News	
Burglaries	5
Candidates for City Council	6
Police Blotter	5
About Town	
Books	18-19
Christmas Tree Lot	10
Helping Women in Africa	17
Performing/Visual Arts	15, 21-22
Preschool Listings	11
Backyard Getaways	2
Balanced Living	18
Business Buzz	24
Calendar	21
Classified	20
Editorial	4
Home Sweet Home	19
Itch to Stitch	14
Orinda Association	3
Seasoned Shopper	10

PRSR STD  
U.S. POSTAGE  
**PAID**  
Orinda, California  
Permit No. 4

BACKYARD GETAWAYS

Backyard Getaways and Beyond  
Into Africa

Bobbie Dodson



As the sun rose, we ate breakfast around a campfire, then boated on the Kwando River to an airstrip where a 12-passenger Cessna took us from Namibia to Botswana. On the game drive traveling to our remote lodge on the border of the Moremi National Park in the Okavango Delta, we spotted giraffes, elephants and impalas and watched four lions lazing in the afternoon sun. At dinner, there was a birthday cake and champagne. Then, as we



Zebras gather at the water hole in the Moremi National Park in Botswana.

headed for our tented cabins, an elephant blocked the path until it was shooed away. What a special way to celebrate my 80th birthday.

The three-week trip to Africa, with Overseas Adventure Travel (OAT, 1-800-873-5628) covered the countries of South Africa, Botswana, Namibia and Zimbabwe. We felt safe the entire trip, had excellent guides, and liked it that our groups are limited to 16. Ours bonded well as we bumped along on morning and evening game drives in open-sided Land Rovers, exclaiming over each sighting of animals and birds. My checklist shows 89 kinds of birds and 37 kinds of animals seen.

Perhaps the biggest thrill came when our guide was following tracks by the side of the road on our return to camp in the dark. Suddenly, the searchlight picked up the eyes of a leopard, glowing red, just a few feet off in the brush. Another day, trackers followed footprints of a rhinoceros. After we joined them, it took another 45 minutes until she came into view. The leopard and rhino were two of the most elusive of the animals labeled as the "Big Five," a goal for African visitors to see. The others are the elephant, buffalo and lion. We saw them all.

Elephants were my favorite. One afternoon, more than 100 of them gathered at a watering hole. They tangled trunks while



CONTRIBUTED PHOTO

Bobbie Dodson makes some new friends at the Lion Preserve in Victoria Falls.

playing; flapped their ears for cooling, waded into the water to shower themselves with spray from their trunks, then came out and blew dust over themselves. The way the mothers carefully tended their youngsters charmed me.

We saw herds of elephants and hippos swim across rivers, always helping the young ones along, positioning them between adults. Giraffes, zebras, wart hogs, wildebeests, various kinds of antelope, buffalo, baboons, vervet monkeys, crocodiles, squirrels, rabbits and impalas were sighted often.

A trip staying at wilderness camps isn't for those seeking rest and relaxation but it provides rich rewards. A typical day required getting up at 6 a.m. when a staff person came to each unit beating a drum. Breakfast at 6:30, then off at 7 for a game drive of three or four hours. These were

broken up by a stop for refreshments (where there were no toilet facilities, only bushes). Back to camp for lunch, a couple of hours on one's own, tea time, often with a lecture, and another game drive with "sundowner" drinks and refreshments. Arriving at the lodge in time for dinner, sometimes followed by dancing and singing by the staff, we were soon escorted to our tented cabins, where we were to stay, safely away from any animals that might come through camp, until the next wakeup time.

But some days were different. We traveled by boat to observe the wildlife when in Caprivi, Namibia – much smoother going than Land Rovers. One morning we went for a mokoro (canoe) ride. We were able to visit several neat and tidy villages with no running water or electricity, dirt floors in the houses, and cooking was done over

[SEE BACKYARD page 16]

WE SUPPORT VICTORIA SMITH FOR CITY COUNCIL!

"As the first Mayor of Orinda, I am so pleased that we have a current Mayor of Victoria's caliber, dedication and experience!" **Dick Heggie, Former Mayor, Orinda**

"Victoria has a solid record of working on behalf of education both as a parent and now as a city council member. If you believe, as I do, that our schools are among our best community assets, then I urge you to join me in voting for Victoria Smith for Orinda City Council." **Pat Rudebusch, Orinda Union School Board Member**

"Victoria has worked tirelessly to find solutions to improve Orinda's infrastructure, to build consensus to fix our roads, and to improve emergency preparedness in Orinda." **John Wyro, Board Member, Moraga-Orinda Fire District**

"Victoria is committed to improving Orinda's roads, bike paths, walkways and trails. She is a strong advocate on the City Council for recreational spaces!" **Shannon Fuller, Orinda Parks and Recreation Commissioner**

"Victoria's support for business in Orinda is outstanding! She really shares our goal to bring more shops and services to Orinda." **Janet Boreta, Orinda Books**



Elected Officials

- Elen O. Tauscher**, Congresswoman
- Tom Torlakson**, State Senator, 11th District
- Mark DeSaulnier**, Assembly Member 11th District & State Senator Elect
- Loni Hancock**, Assembly Member 12th District & State Senator Elect
- Nancy Skinner**, Board Member, East Bay Regional Park District and Assembly Member 13th District Elect
- Richard Rainey**, Former Sheriff/State Senator
- Joyce Hawkins**, Former Orinda Mayor
- Dick Heggie**, Former Orinda Mayor
- Bill Judge**, Former Orinda Mayor
- Bobbie Landers**, Former Orinda Mayor
- Alan Tabor**, Former Orinda Mayor
- Gregg Wheatland**, Former Orinda Mayor
- Amy Worth**, Former Orinda Mayor and Current Council Member
- Riki Sorenson**, President, Orinda Union School Board
- Pam West**, Vice-President, Orinda Union School Board Member

- Glen Alper**, Orinda Union School Board Member
- Jack Bontemps**, Orinda Union School Board Member
- Pat Rudebusch**, Orinda Union School Board Member
- Nancy Kaible**, Former Orinda Union School Board Member
- Linda Landau**, Former Orinda Union School Board Member
- Jean Lyford**, Former Orinda Union School Board Member
- Vanessa Crews**, Acalanes Union High School District Board Member
- Gene Gottfried**, Moraga-Orinda Fire District Board Member
- Pete Wilson**, Moraga-Orinda Fire District Board Member
- John Wyro**, Moraga-Orinda Fire District Board Member
- Katy Foulkes**, Director East Bay Municipal Utility District
- Gail Murray**, President, BART Board of Directors
- Gerald Lucey**, Board President, Central Contra Costa Sanitary District

- Tomi Van de Brooke**, President, Board of Directors, Contra Costa Community College District
- Steve Ybarra**, Contra Costa County Auditor
- Sue Rainey**, Walnut Creek City Council Member
- Tony Thurmond**, Richmond City Council Member
- Joan Buchanan**, Candidate for 11th Assembly District
- Chuck Carpenter**, Contra Costa County Democratic Central Committee Member
- Community Supporters**  
Louise Adamson  
Erick & Heather Andersen  
Dave & Sandy Anderson  
John April  
Wesley Ayers  
Erica Bains  
Carlos Baltodano  
Allison & John Banisadr  
Reg & Kathy Barrett  
Rich Bartlett  
Russ & Mary Belden  
Janet Boreta  
David Bowlby  
Mary Chatton Brown  
Bruce Burrows  
Marti & Jim Buxton  
Wayne & Jo Alice Canterbury  
Jim & Francois Cervantes  
Bill & Marion Cooper

- Catherine E. Cutler and Abe Mintz
- Rebecca Dahlberg
- Ellen & Joffa Dale
- Sylvia Gonos Deaton & Eric Jorgensen
- Bill & Barbara Denny
- Robert & Pat Dunn
- Susie Epstein
- Gabriel Esquivel and Jill Howie
- Bob & Cheri Etheredge
- Dennis & Natalie Fay
- Mary & Andy Franklin
- Gary Fryer
- Shannon & Glenn Fuller
- Dennis & Darlene Gee
- Steve Gentry
- Paula & Mark Goodwin
- Bill & Elizabeth Gross
- Sandy Gross & Paula Reinman
- Kitty Guphill
- Pam & Alan Hall
- Peggy & Ernie Hartz
- Joyce Hawkins and Jack Sweitzer
- Dick & Bea Heggie
- Aram Hodess & Sue Fox
- Elle Hoffnagel & Terry Murphy
- Charles Hogle
- Dwight Holing
- Alison, Jeff, & Kent Holland
- Randy Holleschau
- Keith Horrocks
- Bruce & Jackie Horwitz
- Roger B. James
- Bruce Jett
- Elisabeth Jewel
- Jeff Johnson
- Christie & Jim Jordan
- Bill & Joey Judge
- Nancy Kaible & David Anderson
- Ed & Grace Kaplan
- Rick Kattenburg
- John & Shellie Kirby

- Chris & Anne Marie Kniel
- Eric & Jennifer Knutson
- Mimi Liem
- Sue Littlehale
- Chris & Kathryn
- Don & Vicki Lucas
- Cinda & Tom Mackinnon
- Janet & Vincent Maiorana
- David Mayeri
- Deven & Kimberly Mays
- Terry McBriarty
- Jan & Ralph McDonald
- Joe & Wendy Meckes
- Petra Michel
- Bob Mills
- Gary Moore
- Beth Nevins
- Eartha Newsong
- Kay Norman
- Tom & Karen Norris
- Dean Orr
- Diane Oshima
- Janice Ottonello
- Dean Orr
- Michael & J. Virginia Peiser
- Bill Phelon
- Pam Pulley
- Bob & Ling-Ling Randles
- Sandy Roadcap
- Ben Rodriguez
- Pam Rosendale
- Terry Sandoval
- Dana & Richard Sankary
- Laura Sawczuk
- Steven Schrier
- Erwin & Terry Schrittwieser
- Ron & Karin Sharp
- Joel, Aaron & Danny Sheiman
- Ron Simmons
- Valerie & Larry Sloven
- Caroline Smith

- Nancy Sprague
- Riki Sorenson
- Jay and Linda Steuer
- Carol & Tom Sueoka
- Allan & Suzanne Tabor
- Robert and Maryett Thompson
- Pat & Davis L. Todhunter
- Susan Turner & Stefan Jovanovich
- Lida & Ted Urban
- Jane & Dan Voll
- Kathy & Will Waddill
- Clark Wallace
- Sue & Ron Wecht
- Florence & Carl Weber
- Kim & Jeff Weber
- Susan Weldy
- Heather West & Larry Karp
- Richard Westin
- Jack D. Wickware
- Lucy Hupp Williams
- Jeffery Wolk
- Larry & Radha Wood
- Jim Woodall & Charly Guidry
- Brian & Randi Woods
- Steve & Dana Ybarra
- Irene Yee & Robert Scheive
- Midge & Peter Zischke

- Community Organizations**  
National Women's Political Caucus of Contra Costa  
Sierra Club  
League of Conservation Voters of the East Bay  
Central Labor Council of Contra Costa County  
Democratic Party of Contra Costa County  
Operating Engineers, Local 3, District 20, AFL-CIO

ORINDA ASSOCIATION

A Message From the OA –  
Enjoy More Benefits

April Meagher, Membership Chairman



As Thanksgiving nears, we are making plans to travel and spend time with family. The holidays always make me reflect on how lucky I am: good health, two beautiful daughters, family close by, and a community that I really enjoy living in. I didn't grow up in Orinda and appreciate every day what a vibrant area it is. My husband did grow up here and very much wanted to raise his children in the community and schools that he knew so well. I know that many of you feel the same way and are also raising your family in Orinda, the same town you grew up in. And some, like me, just couldn't wait to be a part of this special place!

Some of the best features of this community are the events that tie us all together. Many of us stay in town to enjoy the OA's 4th of July Parade and park activities. This year, we were also blessed with a wine tasting and silent auction on July 2 called "Reach for the Stars." We all benefit by the OA Volunteer Center, which runs the Seniors Around Town program, the Soccer 4 All program, and coordinates volunteer activities as needed. Seniors Around Town provides volunteer drivers to take local seniors on errands and to doctors' appointments while Soccer 4 All takes donated, gently used uniforms and matches them with soccer teams in less fortunate countries or underserved areas locally.

The Orinda Association is responsible for all of these community programs. In addition, the OA recognizes the contributions of others at the annual Volunteer of the Year dinner. This year's event takes place on January 25, 2009, and we hope you will join us to honor this year's recipient of the Volunteer of the Year and the William Penn Mott, Jr. Environmental award.

Believing that all Orinda residents should be informed about issues that affect residents, the OA hosted a candidates' forum this past October where the three candidates running for city council could discuss their priorities for Orinda. The OA also publishes *The Orinda News*, which makes its way to every Orinda household and business at no cost to them.

All of these activities and programs would not be possible without the support of our members. This year, we want to make your membership more valuable than ever. We have partnered with local busi-

nesses that offer special discounts only to OA members. The following businesses participated this year: Subway, Fed Ex Kinko's, Treible Stationers, Petra Café, Entourage Spa, AJ Nails, and Shelby's Restaurant. The cost of your membership can be returned back to you just by using your membership card at local businesses for special discounts or free products. If you already frequent these locations, why not become a premiere client and turn the cost of your membership into savings at these local businesses?

Are you still hesitating about joining the OA? I want to give you a few more reasons to say Yes to OA Membership. We are a 501 (c)(3) non-profit organization, therefore, your membership is tax deductible. And, starting November 1, you can log on to our website ([www.orindaassociation.org](http://www.orindaassociation.org)) to renew your membership with a credit card. You can also write a check and put it in the envelope inserted in this issue of *The Orinda News*. It just couldn't be easier or more beneficial to become a member this year!

I sincerely hope that as you plan your holiday with family you count yourself as blessed as I do. I hope that you, too, are in good health, have loving family nearby, and

are proud that you live in Orinda. Please take the time to help the Orinda Association continue to make our community thrive. All we ask is membership. What you get back in return is golden.

**Volunteer of the Year  
& William Penn Mott, Jr.  
nominations due December 1.**

The Orinda Association

P.O. Box 97  
26 Orinda Way (Lower Level Library)  
Orinda, California 94563  
Phone: 254-0800 Fax: 254-8312  
[www.orindaassociation.org](http://www.orindaassociation.org)

OFFICERS

Co-Presidents	Jim Luini, Kate Wiley
Co-Vice-Presidents	Barnaby Beck, Steve Meagher
Treasurer	Barnaby Beck
Secretary	Tony Ratner
Membership	April Meagher
July 4th	Cindy Powell
OPSAC Liaison	Bill Waterman

**Save Money on Gifts!**

**Christmas Shopping at Bargain Prices,**  
Fine Jewelry and other gift items brought in for  
Holiday shopping.  
Also, new rugs and unique one of a kind furniture.

*Hilton House*  
Consign and Design.

21 Orinda Way  
Orinda, CA 94563  
(925) 254-1113  
[www.hiltonhousedesigns.com](http://www.hiltonhousedesigns.com)  
Hours: Mon. - Sat. 10 a.m. to 5:30 p.m.

Help our planet. Don't Buy New!  
Think about it. When you choose to purchase  
pre-owned furniture from our store, you are  
saving money and helping our planet stay green.  
It's a win-win way to furnish - so why buy new?  
Think Green... We'll Help!

**Zamboni's**  
PIZZA CO.

presenting

- Regular & Chicago style pizza
- Fresh, high quality ingredients
- Gourmet specialities
- Pizza by the slice at lunch
- Salads
- Fast, free, on time delivery for lunch, dinner, parties and special events

1 Camino Sobrante, Suite 4  
254-2800  
Open 7 days 11-10 p.m. Monday - Saturday  
11-9 p.m. Sunday

**Are you a local Orinda Business? How would you like more local customers, free advertising, and an increase in your business?**

Partner with the OA and find out how. Contact:  
April Meagher  
Membership  
Orinda Association  
(925) 254-5776  
[Aprilmay\\_27@yahoo.com](mailto:Aprilmay_27@yahoo.com)

**WHAT ABOUT US?**

47 year Orinda Residents

**Finally, someone who will represent our interests!**

**DR. BOB LARSEN**  
ORINDA CITY COUNCIL

Paid For By: Dr. Bob The - Alternative

Phone me at: (925)254-1917 or Visit my blog at: [drbobthealternative.com](http://drbobthealternative.com)

EDITORIAL

**Editor's Note:** Due to the number of letters to the editor, there will not be an editorial this month. You can find additional letters on our website, [www.orindanews.org](http://www.orindanews.org). Click on the web edition for November and go to page 25.

**Corrections:** In the October issue of *The Orinda News*, the caption on pg. 19 was incorrect. It should have read Showboat, a 1929 Packard, shown here with Bernard Maybeck's identical twin granddaughters, Adriana and Sheila Maybeck, and their grandmother Helene Van Huizen.

Letters to the Editor

**Moraga Way Rehabilitation Project**

My compliments and appreciation for Mayor Smith's attention to improving the city's approach to rehabilitation of our roads.

After contacting the city manager and being advised by the city engineer that no more than pothole repair would be performed, in the August issue I criticized the city for neglecting the roughly one half mile segment between the south and north intersections of Camino Encinas with Moraga Way. My point being that this segment would have amounted to an increase of perhaps 10-15 percent, or maybe \$50,000. Not the half-million dollars suggested in the September issue by a practitioner of fuzzy math, as well as her unfounded assumptions. What would have been the reaction if the portion between the two Ivy Drive intersections been excluded? (Approximately one third of the project.)

Fortunately, the city seems to have found a way to patch perhaps 40-50 percent of the neglected portion, but I doubt that this cost significantly less than had the segment been included in the rehabilitation contracts. It's too bad that we couldn't have taken advantage of the main contract for economy of scale including avoidance of multiple mobilization and demobilization costs.

- C. Burke Gordon

**Relieving Teen Boredom**

I am disappointed in the lack of entertainment and activities that are available for teens in Orinda. What Orinda needs is a safe hangout spot where kids can chill out and do fun activities. With gas prices as they are, teens are more hesitant to drive out of the city to find amusement. So, we need a place to have fun! There are a few spaces around town that could be perfect for a teen venue. First, there's the Phair's building, which is quite large and could even fit a small bowling alley. There is also the park and community center that could house a music or movie venue with teen interest, which could even house local teen bands. Finally, there are a few vacant Theatre Square buildings that could easily house small boutiques. These shops would improve Orinda's economy. Even if none of these venues are options, there are still things that can be done for entertainment. Teen movie nights or other events could be organized with a little bit of hard work. Last, but definitely not least, it would

be nice to have teen travel opportunities available. These ideas can boost Orinda's economy and reduce the teens' boredom.

- Alicia Macler

**Benefits of Orinda Bubble**

I wanted to write to you to tell how sorry we must all feel for Andra Lim (the student who has posted two consecutive rants on the demerits of living and growing up in Orinda). She obviously has a chip on her shoulder and needs to find a positive outlet for her feelings.

I think it would be great for *The Orinda News* to publish stories submitted by students who have benefitted from "the Orinda bubble." Fortunately, they are all probably all off at college learning to grow up.

- Scot Ferguson

**Racial Profiling**

The September 2008 headline on the editorial said, "Does Racial Profiling Exist Here in Orinda?" I was curious to see what the op-ed piece had to say and was saddened that this little town that appears to have changed so much in its politics since I moved here 24 years ago is still looking at "other" as suspect.

While the tone of the piece was generally fine, there was one telling sentence near the end: "Unfortunately, Orinda has a small number of African-Americans living in its boundaries, making black residents and visitors stand out." I understand the intent of the writer, however, better editing would have made that sentence not sound as if it's unfortunate that there are any African-Americans. Perhaps the author could have written: "Unfortunately, Orinda has only a small number of African-Americans..." or "Unfortunately, the diversity of Orinda's population is limited, making black residents and visitors stand out."

Otherwise, thank you for printing this op-ed piece.

- Theresa Larson

**Giving Residents a Voice**

As an interested resident of the City of Orinda I routinely attend city meetings whether of the city council or one of the city's committees, task forces or commissions. There is usually a mechanism for giving input through the public forum component at city meetings. I certainly support having input in that fashion. I realize there are some restrictions about how meetings can be run in compliance with the Brown Act. I am supportive of the idea that city



government involve its residents and obtain their input on matters of importance for governance.

I am not the first resident to suggest the idea of a "citizen ombudsman" to be utilized by the City of Orinda in representing its constituents. It would be helpful if there was a designated liaison that residents could go to with the authority to look into matters beyond what other staff have time for. I conceptualize this position as a quarter-to-half-time position. The city could partner with the local universities in sponsoring an internship which would make this a low-cost endeavor. The School of Public Policy at U.C. Berkeley, the School of Business at St. Mary's College and an appropriate department at J.F.K. University would be natural potential partners. These schools of higher education have as part of their mission maintaining ties to local communities. Internship programs are promoted at these colleges as a means of giving students real life experience.

Communication between city hall and the residents of Orinda is a crucial element to effective representative government. The proposed citizen ombudsman program has the potential for helping Orindans with their concerns and complaints. We have local talent that is available to help us in developing such a program. This would be a supplement to the existing open forum and would not undermine those important efforts.

Thank you for your consideration of this community issue.

- Dr. Bob Larsen

**Grateful to Glazer**

As an active and involved community member, I have had the chance to observe the work of the city council these past few years. The council is working with limited resources yet have high demands from residents who want better roads, balanced and timely consideration of remodeling permits, safety programs and fiscal responsibility. It is not an easy job.

I want to call out the fine work of last year mayor and current councilmember Steve Glazer for his excellent leadership in bringing all elements of the city together to make progress on all the matters mentioned above. His open and consensus-driven stewardship has provided a place for all citizens at the decision-making table. He does not view his job as having all the answers but rather working with interested and knowledgeable residents to find the best solutions.

In particular, I want to mention Steve's leadership in keeping the school district's Pine Grove plan from collapsing. About 20 months ago, our developer, Pulte Homes, was in a technical default position due to unhappiness with excessive regulations from the city. The school district stood to gain \$25 million from the completion of this project for much-needed capital improvements. Steve chaired an emergency council and Planning Commission committee comprised of one other councilmember, city staff, school district staff and school board members to review the problem and search for common ground. The project plans were revised. Compromises were made. The Orinda Union School District staff and board members were delighted when the council approved the project last week. It is worth noting the vote was unanimous with no member of the public objecting. I would like to sincerely thank all members of the council - Sue Severson, Victoria Smith, Tom McCormack and Amy Worth - but want to especially recognize Steve Glazer's good work. The level of trust, cooperation and responsiveness toward the school district has increased dramatically during Steve's tenure and is much appreciated. I hope you will join me in supporting his re-election to the council.

- Pamela West

[SEE LETTERS page 20]

*The Orinda News* prints 9,000 copies and is published 12 times a year by The Orinda Association. The office is located at 24 Orinda Way (lower level of the Library). All rights reserved. The publication is sent out by direct mail (Permit #4, Orinda Post Office) and distributed to key locations throughout the city.

Editor..... Sally Hogarty  
 Assistant Editors .....Chris Lavin, Pat Rudebusch  
 Advertising Representatives.....Jill Gelster, Candy Kattenberg  
 Editorial Committee..... Sally Hogarty, Chris Lavin, Jim Luini, Cindy Powell, Pat Rudebusch, Kate Wiley  
 Staff Writers.....Dorothy Bowen, Andrea Colombu, Bobbie Dodson, Janice Gatlin, Valerie Hotz, Barbara Kobsar, Doreen Leong, April Meagher, Elana O'Loskey, Moya Stone  
 Contributing Writers ..... Gabriela Chavet, D.D. Felton  
 Graphics .....Aspen Consulting: Jill Gelster & David Dierks  
 Printing.....Folger Graphics

The Orinda News

A Publication of  
 The Orinda Association  
 Mailing Address  
 P.O. Box 97  
 Orinda, California 94563  
 Telephone: 925 254-0800  
 Fax: 925 254-8312  
[www.orindanews.org](http://www.orindanews.org)



Opinions of *The Orinda News* are expressed on the editorial page. Views of writers and letters to the editor are their own and do not necessarily reflect the views of The Orinda Association or of *The Orinda News*. Advertisements appearing in *The Orinda News* are not to be construed as endorsements by The Orinda Association or *The Orinda News*.

Letters to the Editor are printed on a space-available basis and should be no longer than 400 words. They must include the writer's first and last name, signature and telephone number.

Send letters to: Editor, *The Orinda News*, P.O. Box 97, Orinda, CA 94563, fax them to 254-8312, or email to [news@orindaassociation.org](mailto:news@orindaassociation.org). Letters to the Editor for the December issue are due November 5, 2008.

For display advertising rates, call Jill Gelster at 925-528-9225 or email to [jill@aspenconsult.net](mailto:jill@aspenconsult.net). The deadline for the February issue is January 15, 2008.

CHAMBER OF COMMERCE / POLICE BLOTTER

Police Apprehend Suspects in Orinda Burglaries

By SALLY HOGARTY  
Editor

As of press time four suspects had been arrested for residential burglaries that occurred during the months of August and September in Orinda, Lafayette, and unincorporated Walnut Creek. Some of the items stolen were recovered in a Pittsburg home with additional property recovered from two Antioch pawnshops.

Orinda Police Chief Bill French called in extra patrols and received additional help from the Contra Costa Sheriff's department and police officers in Antioch and Lafayette. "We have been working very hard to solve these crimes," says French. John Charles Walters, a 32-year-old felon, is suspected to be the possible leader in these burglaries. He has so far evaded police, but French feels his capture is eminent.

"These people may be trying to blend in as delivery people since they are able to carry out large objects like flat screen TVs

in broad daylight without anyone reporting anything suspicious," he adds.

Chief French asks residents help in preventing future burglaries by having an audible alarm system and always using it. "I know it is a hassle to turn it on when you're just running out for a short time, but this is just what burglars are looking for – an empty house without an alarm. They can be in and out in no time."

French says Orinda topography can also be helpful to burglars. "Many of the houses are isolated or on a lot large enough that a neighbor might not see someone coming up to the door or hear glass shatter as someone breaks in," he says.

According to French, burglars do not want to encounter people in the homes. They usually go to the front door and knock. If there is no answer, they will try and open the door or go around to the back and break-in. He encourages residents to

[SEE POLICE page 20]

Chamber of Commerce Restaurant Tour a Big Success



CANDY KATTENBURG

(L-R) Janet Riley, Holly Henkel, and April Matthews (with hands up) celebrate at the Educational Foundation of Orinda (EFO) table when the announcement of the sale of Allison McCrady's painting "Looking West" was made. McCrady's painting was auctioned for \$500 with half of the proceeds going to EFO. The lucky top bid for the painting was from Roberta Taner. Two hundred and twenty-three booklets for the first annual Orinda Restaurant Tour were sold resulting in an additional \$2,230 donation to EFO. Attendees came to Theatre Square to pick up their booklets and a wine glass before strolling to the participating restaurants for a variety of delectable goodies. Many returned to the EFO table at Theatre Square to enjoy pies donated by Nation's Hamburgers and coffee donated by Peet's Coffee and Tea. Orinda's former mayor Joyce Hawkins said, "I hope that this restaurant tour is the first of many."



POLICE BLOTTER

September 2008

**False Residential Alarms:** Officers responded to 148 false alarm calls throughout the city.

**Auto Burglary** (theft from a locked vehicle): 4 incidents.

**Petty Theft From Vehicle** (theft of less than \$400 value from an unlocked vehicle): 6 incidents.

**All Other Petty Thefts:** 4 incidents.

**Grand Theft From Vehicle** (theft of more than \$400 value from an unlocked vehicle): 4 incidents.

**All Other Grand Thefts:** 1 inci-

dent.

**Residential Burglary:** 10 incidents.

**Commercial Burglary:** 1 incident.

**Vandalism:** 13 incidents.

**Arrests**

**Warrant Arrest:** 4

**Drugs – Under Influence:** 1

**Driving Under the Influence:** 3

**Petty Theft:** 1

**Commercial Burglary:** 1

**Public Drunkenness:** 6

– Compiled by Jeanette Irving,  
Orinda Police Department

Casa de Gracia - A Beautiful Home for the Elderly

- Intimate, quiet home with beautiful views
- 24 hour personalized care
- Enhanced social activities programs
- Dementia, Non-Ambulatory and Hospice services available
- Family Owned and Operated since 1998
- M.D. /R.N. Supervised



(925) 254-4535

Tahos Rd. • Orinda 458

License #075600243

Motorists Duped into Dumping Dough at Dealerships

Federal Law states a manufacturer cannot deny any warranty claim due to maintenance being performed by an independent repair shop. Many consumers have been led to believe that they are required to return to the dealership for maintenance of their

vehicle. This is not true according to the law. In fact it is illegal for any dealership to state or imply that your vehicle must be serviced by them to keep the warranty valid. You have a choice about servicing your vehicle.

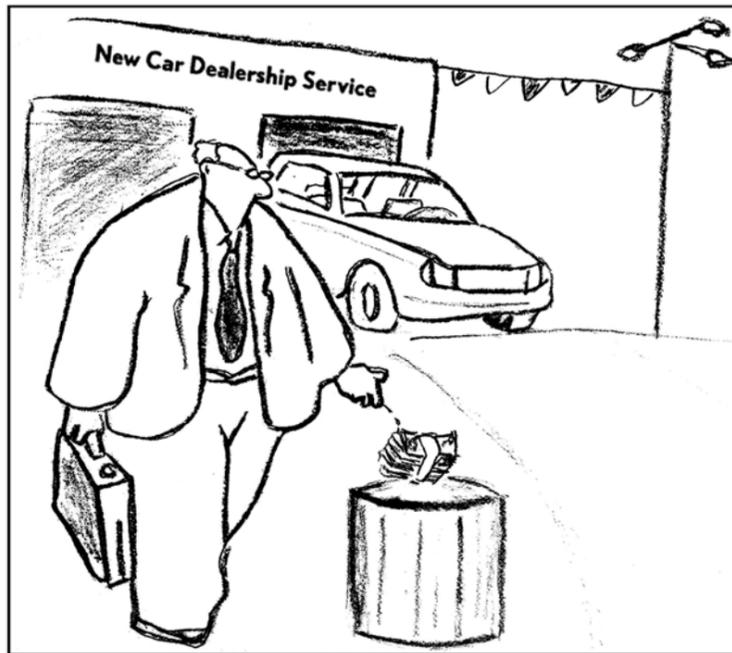

Don't dump your dough if you don't have to.

Orinda Motors Is the Smart Choice!

Get the most value and convenience for your dollar.

Recent repair shop comparison has been performed:

	Orinda Motors	Dealership
Service Keeps Your Warranty Valid	Yes ✓	Yes ✓
Factory Trained Technicians	Yes ✓	Yes ✓
State of the Art Diagnostic Equipment	Yes ✓	Yes ✓
Access to Factory Repair and Service Info	Yes ✓	Yes ✓
Tires and Alignment	Yes ✓	Some
Emissions Testing	Yes ✓	Some
On-Site Rental Service	Yes ✓	Some
Complimentary Vehicle Pickup & Delivery	Yes ✓	Some
Trust - Always Get What You Pay For	Yes ✓	Some
Excellent Customer Service	Yes ✓	Some
Green Business	Yes ✓	Some
Open Door Shop Policy	Yes ✓	No
Locally Owned / Family Business	Yes ✓	No
While You Wait / Drive Through Service	Yes ✓	No
Access to Your Vehicles Technician	Yes ✓	No
Conveniently Located In Your Home Town	Yes ✓	No
Local Community Support and Involvement	Yes ✓	No

Orinda Motors Inc., 63 Orinda Way, Orinda, Ca., 94563 (925) 254-2012

www.orindamotors.com



CANDIDATES FOR CITY COUNCIL

Glazer, Larsen, and Smith Vie For Two Seats on the Orinda City Council

The five members of Orinda's City Council are elected volunteers who set policy, give direction to staff, and make budget decisions. Besides attending twice-monthly council meetings, each council member serves on several committees. They also interact with the various levels of government between the city and the state on issues such as transportation, smart growth, and traffic.

**Questions Asked**

The editorial committee of *The Orinda News* asked the following questions to the three candidates running for two seats on Orinda's City Council. Steve Glazer and Victoria Smith are seeking re-election to their second term on the council and Bob Larsen is running for his first term as a councilmember.

1. What qualifications and/or relevant experience do you bring to the position of city councilmember?
2. Would you characterize Orinda as pro-business, semi-rural, a bedroom community, no growth, or something else? Would you work to move it in a particular direction or would you want it to stay as it is?
3. Empty storefronts in Orinda, and especially in Theatre Square, have been of concern for several years. How would you support current businesses and attract new businesses to Orinda?
4. How should the City of Orinda address the remaining infrastructure problems, including improved walkways and bikeways?
5. How would you rank, in order of importance, three areas of need in Orinda and what can you bring to the job to move these areas forward?



CONTRIBUTED PHOTO

**Steve Glazer**

■ **Qualifications**

I have served three and one-half years as an Orinda City Councilmember and a term as mayor. I previously served on the Park and Recreation Commission. Additionally, I have chaired or taken on senior responsibility on community committees working to expand the library hours, provide stable funding for our schools and expand paramedic services to all fire stations. In my professional life, I am a strategic and communications consultant retained by companies, organizations and governments to solve difficult public policy problems. This background has provided me with the experience and skills to work with our Orinda citizens in maintaining our excellent quality of life in a fiscally responsible manner.

My local experiences provided the basis for my council work these past few years to make city government more open and accessible to residents, promote improvements to our planning and design review process, increase public safety and emergency preparedness activities, and direct city resources toward fixing the most traveled roads, such as Moraga Way, Glorietta, Lombardy and Camino Pablo. It is also

these experiences that have made building stronger relations with the Orinda Union School District an important city goal.

■ **Characterize Orinda**

Orinda is a quaint village where families and seniors can enjoy a high quality of life in a community that loves nature, enjoys the arts and is inspired by a diversity of religions, cultural, and recreational experiences. I think the goal for elected officials and residents alike is to protect this special quality of life today and for the future.

■ **Support Business**

Orinda's restaurants, retail shops, banks, service and professional offices are an important part of our town. The sales tax money generated help fix out roads and provide public safety services. The convenience of shopping local also keeps cars off the roads, reducing pollution and greenhouse gas emissions.

The City of Orinda has been partnering with the Chamber of Commerce to promote local businesses (Shop Orinda) and our great restaurants (A Taste of Orinda). A non-profit foundation has been started by local residents to look for ways to protect the Orinda Theater. We also have a task force of residents examining ways to improve the overall appearance of the downtown. The city's proposed purchasing policy gives added weight to the purchase of goods provided by local vendors.

The city needs to continue to look for ways to reduce bureaucratic red tape in order to attract and retain a vibrant commercial downtown.

■ **Infrastructure**

According to our citizen's Infrastructure Committee, Orinda has a road and drain repair deficit of approximately \$100 million. With an entire city operating budget that is about one-tenth that size, our ability of ever getting in front of this problem with existing resources is remote. Our infrastructure failures are certainly the most important issue facing the city. The city council has taken five actions to improve the current

[SEE GLAZER page 7]

**THE ART OF RACING IN THE RAIN**  
A NOVEL  
GARTH STEIN  
HARPER • \$23.95

**meet the author**  
**thursday, november 13**  
**4 pm**

*a beautifully crafted and captivating look at the wonders and absurdities of human life... as only a dog could tell it.*

**ORINDA BOOKS**  
276 VILLAGE SQUARE • 925/254-7606  
MONDAY-FRIDAY 10-6, SATURDAY 9-5, SUNDAY 11-4 • WWW.ORINDABOOKS.COM

**Save Gas  
Save Time  
Save Money**

Shop Your Local Orinda McCaulou's

---

**Bring in this  
Coupon**

One Time Purchase – Storewide

20%  
OFF

Good in Orinda Only. Present Coupon at point of purchase for 20% Off one time purchase. 1 coupon per family. Not valid on previous purchases or other coupons. No cash substitutes.  
Exp. 11/30/08

---

McCaulou's

250 Village Square Orinda (925) 254-3448  
Monday – Saturday 10:00 – 6:00

CASA ORINDA

RESTAURANT

Dinner served nightly from 4 pm

925.254.2981 ■ 20 Bryant Way ■ Orinda, CA 94563

CANDIDATES FOR CITY COUNCIL

◆ **GLAZER** from page 6

situation.

First, the city budget has been cut and trimmed in order to put more funds toward street repairs. In the past two years, the council has increased road spending substantially.

Second, citizen input has been greatly expanded. A citizen's infrastructure committee has been established to review and advise the city council and community on infrastructure spending and policy. Additionally, a citizens' task force has been assembled to examine options for raising revenue from new sources. Their report is expected later this fall.

Third, the city has adopted new spending priorities that focus available dollars on the most traveled roads and where we can get the most bang for each dollar. That is why you are seeing repairs to major streets such as Moraga Way, Camino Pablo, Glorietta and Lombardy rather than cul-de-sacs.

Fourth, city staff has been tasked with applying for all possible regional, state and federal grants for street repair.

Fifth, the city is partnering with utilities wherever possible to take advantage of their planned work under the roads. For example, this will allow future repaving work on Miner Road.

community together and find a consensus solution. We will never be able to please everyone, especially when it comes to new taxation. In a community that is blessed in so many ways; great schools, beautiful surroundings, educated and affluent citizenry, I hope the residents and the new city council will roll up their sleeves and work for an achievable solution to this vexing problem.

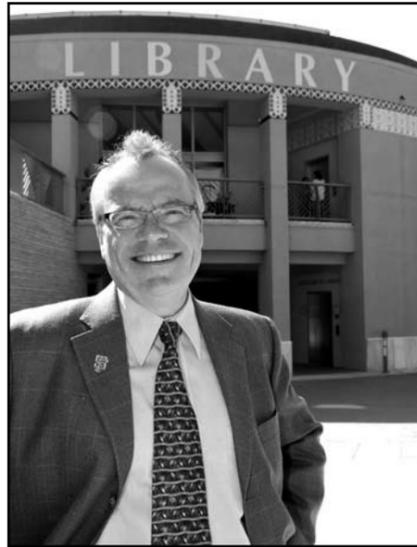

CONTRIBUTED PHOTO

**Robert Larsen**

■ **Top Concerns**

The top areas of concern are roads, roads and roads. Every day, our residents are paying for our poor road conditions with increased maintenance costs and early tire replacements. Roads in disrepair create safety hazards for walkers and cyclists. The city and ultimately the taxpayers are vulnerable to liability costs due to claims of unsafe roads. Road collapse can be a multi-million dollar fix and can prevent residents from accessing their property. Experts in road construction and repair have made it clear that the cost for road repairs goes from a 1x cost if done before the damage is too bad to a 5x fix when there is road failure. Forty percent of Orinda roads are now in failure condition.

It is penny wise but pound foolish to let this problem fester for any more years. It is true that when the City of Orinda separated from the county in 1985, we inherited 92 miles of substandard roads and drains. It is also true that Orinda ranks last out of 100 Bay Area cities in road condition. We have had two elections where a comprehensive repair plan received 64 percent of the vote, just short of the two-third requirement. I'm running for re-election to the council because I don't think we can afford to give up on this problem. We need to bring the

■ **Qualifications**

My career includes molecular biologic research at four universities. I value critical thinking. As a physician, I'm responsible for decisions regarding others' lives. Trained as a psychiatrist, I deal with human emotions and behavior daily. I recognize and have recommendations for individual and organizational dysfunction. I have additional training in public health. Statistics and public welfare are not obscure concepts to me.

With two dozen years experience as a successful businessman and educator, I now wish to serve Orinda. We have untapped talent waiting to improve our community. I intend to be an example of citizen participation. I will be brutally honest. Experienced residents will be involved without concern for ties to the council. Let us walk the walk, not merely talk the talk.

I'm first generation American. I grew up with Depression-era parents who emphasized values of diligence, fiscal responsibility and planning. I've been president of a state professional organization, testified in Sacramento, served 13 years on a state council, and developed regulations affecting the lives of millions of Californians. My intention is to represent you, the citi-

zens of Orinda.

■ **Characterize Orinda**

Orinda is now semi-rural. As a Spanish land grant, this area was rural ranchland. Things change. I have a vision of change for the better. This includes a more vibrant business environment. Our town does not have the reputation of being "pro-business," but it can.

I foresee an Orinda that places emphasis on small business while maintaining its bucolic character. This won't happen by accident or happenstance. We cannot just

build more homes while neglecting commerce and necessary services. Let's work together to increase sales and commercial property tax while improving convenience. This will increase revenue for city services and school funding yet reduce the need for more bond measures tied to residential property. We should be smart about Orinda's future.

■ **Support Business**

Shopping bags encouraging people to Shop Orinda won't do it. We need a real [SEE LAWSEN page 8]

**TREIBLE  
OFFICE SUPPLIES STATIONERS**

FULL LINE OF OFFICE PRODUCTS  
PRINTING-BUSINESS CARDS & STATIONERY • COMPUTER SUPPLIES  
OFFICE FURNITURE • LAMINATING • FAX • COPIES • COLOR COPIES

**254-3643**  
Fax # 254-9720  
19 Orinda Way

MONTHLY BILLING FREE DELIVERY

**Computer Trouble?**  
*Since 2001, Portable CIO has been quickly solving PC and Mac computer problems for small business and individuals.  
How can we help you?*



- Repairs • Upgrades • Networking
- Virus/ Spyware/ Adware Removal
- Office Moves • Internet
- Back-up Solutions
- Data Recovery Solutions
- Maintenance • Email Solutions
- Remote Phone Support
- Free Recycling

**925.552.7953**  
www.ThePortableCIO.com  
*mention this ad for \$10 off your next service*



*The Medicine Shoppe®* **The pharmacy in your neighborhood.**  
Pure Pharmacy<sup>SM</sup> 100%

**We at the Medicine Shoppe® would like to take this opportunity to thank our customers for their continued patronage.**

Happy Thanksgiving

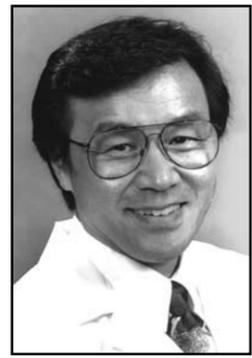

Medicine Shoppe  
Alan Wong, R.Ph.  
Next to Hollyhock and McCaulou's  
282 Orinda Village Sq. • 254-1211  
©2002 Medicine Shoppe International, Inc.,  
A Cardinal Health Company  
www.medicineshoppe.com

Alan Wong, R.Ph.

**IT'S APRIL IN ORINDA**  
!In Lafayette and Moraga too  
**Homes People Together**

dreamhomelamorinda.com or www.villageassociates.com



**APRIL MATTHEWS**

925.253.2147  
aprilmat@comcast.net



CANDIDATES FOR CITY COUNCIL

◆ **LAWSEN** from page 7

plan. This may well include hiring a consultant with a track record for revitalizing downtowns of small cities. Many Orindans bristle at comparing business here with neighboring cities like Lafayette. This year Lafayette will bring \$2.3 million in sales tax while Orinda will settle for about \$900,000. This results in an over emphasis in our city on property tax and bond measures as the solution to recognized needs.

Orinda needs a strategic plan to recruit desirable, small business. Residents should be involved in identifying existing business that is patronized while acknowledging regional shopping that we'd just as soon have here. The potential list includes a small luxury hotel, bed and breakfast inns, a sporting goods store, a medical aids supply

shop, a bowling alley, a high-end used car lot, and the list goes on.

Theatre Square can be a treasure. It needs signage at the very least. Yet, ultimately that business site should be part of an overall plan which includes more frequently cleaning up the trash and making our downtown more attractive. Beautification grants are available. The local garden clubs have helped.

My campaign has used an Orinda business to design ads and arrange printing. I support the efforts of the Chamber. Let's not use Highway 24 as the excuse for sub par commerce.

■ **Infrastructure**

Everyone agrees that roads and infrastructure are primary concerns for Orinda.

The current council supported two failed bond measures. The last required a special election, which was costly for the city.

I, amongst other citizens, advised that a serious revision take place of the initial measure which failed. That didn't happen. The council pats itself on the back for obtaining a \$1 million grant on the \$2.3 million Moraga Way paving while roads and pipes throughout town are crumbling.

All sources of contribution to the infrastructure improvements must be explored. This was suggested to the council before the second failed bond measure. EBMUD, the fire district and other potential partners must be involved. Improving revenue to Orinda will help. Reviewing our city's income/expense sheet should also be considered. Only after all sources of potential contribution to the project are examined should we fall back on another bond measure. When doing so, let's be honest about the need to sacrifice.

■ **Top Concerns**

Business, business, business.

We need a plan to attract and maintain small business that meets the needs of our community. The reality is we hemorrhage revenue to Lafayette, Walnut Creek and other cities. Where is a visitor to stay in Orinda? Where are seniors to purchase medical supplies? Where are teens to find safe entertainment in town? This change can be for the better.

Orinda has tremendous management, financial and professional expertise available in our city. I intend to call upon these human resources to move us toward shared goals of improving government efficiency, fiscal responsibility, and technical competency. Our town must grow up and be more businesslike while safeguarding our semi-rural beauty.

I will bring real business experience with personnel matters, leasing, insurance and government regulation to the city council. The council has the opportunity to move from a model of the PTA to more mature, professional governance representing all citizens, not just the in crowd.



CONTRIBUTED PHOTO

**Victoria Smith**

■ **Qualifications**

I have a long history of volunteering in Orinda. Twenty years ago, when our children were babies, my husband, Wick, and I decided to move back to his home town of Orinda. We became involved in the community through Scouts, OYA sports and schools, and served on four Parent's Club boards. Thirteen years ago, I moved my law practice to Orinda and became an active member of the Orinda Chamber of Commerce. I was appointed to the Contra Costa County Family and Children's Trust Committee, and in 2003, was appointed to the Orinda City Planning Commission. In 2004, I was elected to the Orinda City Council.

With the support of our community, I am running to win re-election to the Orinda City Council this November. Although we have accomplished a great deal over the last four years such as rebuilding Moraga Way, including \$1.7 million of state grant funding, improving traffic safety, collaborating with the Chamber of Commerce and other civic groups to promote the downtown, creating an Emergency Preparedness Plan, and securing long-term financing to operate our beautiful library, a lot remains to be done.

■ **Characterize Orinda**

Orinda is a wonderful, small community that collectively cherishes the unique things about itself – its small-time community feeling, its volunteerism, outdoor spaces and fantastic public schools – and we want to maintain those great elements while we make additional improvements.

With strong support from the council and [SEE SMITH page 9]



**Mary Chatton Brown**  
 & Associates, Realtors

*Proven Personal and Professional Service  
 for All Your Real Estate  
 Investment Decisions*

*Independent Local Real Estate Office Since 1983*  
 12A Orinda Way, Orinda, California 94563

[marychattonbrown.com](http://marychattonbrown.com)      925•254•4994



**Is your dog ruling the house?  
 Reclaim your kingdom!**

The in-home Leadership Program is for you. This program teaches:

- loose leash walking
- coming when called
- sit and down stays
- not to jump on people
- housetraining

Enjoy a happy, calm home again.  
 Please visit [www.italkdog.com](http://www.italkdog.com) for more information and other services.

**Denise Collins**  
 TRAINING COACH

925-285-9194  
[denise@italkdog.com](mailto:denise@italkdog.com)  
[www.italkdog.com](http://www.italkdog.com)

ONE-ON-ONE COACHING  
 FOR THE ULTIMATE RELATIONSHIP WITH YOUR DOG

**Bring in this  
 Coupon**  
 One Time Purchase – Storewide

**20%  
 OFF**

Good in Orinda Only. Present Coupon at point of purchase for 20% Off one time purchase. 1 coupon per family. Not valid on previous purchases or other coupons. No cash substitutes.

Exp. 11/30/08

Greeting Cards	Travel Ledgers	Unique Gifts	Books
Stationery	Puzzles	Aromatherapy	Paper Plates
Gift Wrap	Seasonal Cards	Journals	Napkins
Ribbon	Boxed Note Cards	Address Books	Candles
Calendars	Thank You Notes	Photo Albums	Picture Frames
Guest Books	Gift Bags	Conversation Starters	Bridge Items

And Much More!

**Hollyhock**  
 220 Village Square Orinda (925) 253-9950  
 Monday – Saturday 10:00 – 6:00

**Martinez Recycling**  
**Premium Almond Firewood**  
**16 inch - 2 years old**  
**\$400 per cord**  
**16 inch Mixed Stove Wood**  
**\$275 per cord**  
**Free Delivery**

**925-370-1211**

**Shellie Abbes Kirby**  
**A Realtor for Lamorinda**  
**Second Generation Orindan**  
**Specializing in Orinda Real Estate**



**She knows the community.  
 She knows the market.**

**Office: 925-253-6321**  
**Cell: 925-872-4257**

email: [shellie@shelliekirby.com](mailto:shellie@shelliekirby.com)



CANDIDATES FOR CITY COUNCIL

◆ SMITH from page 8

community volunteers, I am proud of many accomplishments over the last four years. These include: first and foremost, the successful completion of a major road repair project on Moraga Way which completely rebuilt that important arterial, including the use of state funds that we worked hard to secure; the creation of a Traffic Safety Advisory Committee, at my request, which has improved traffic safety in Orinda by creating a blueprint to resolve traffic "hot spot" areas; collaborating with the Chamber of Commerce to promote "Shop Orinda" to improve sales tax revenue; developing an improved emergency disaster preparedness plan with Lafayette and Moraga; "hiring" canine officer "Chef" to assist in locating missing children and fragile seniors; and bringing donated art to public places.

I will work with the community to preserve the unique nature of Orinda, while at the same time actively seek to bring new businesses, goods and services to Orinda.

■ Empty Storefronts

I have always been an advocate for improving the downtown by bringing in new goods and services. The council agreed with me this year to commission a sales tax leakage study; that study will tell us what Orinda residents are going elsewhere to purchase, so that we can work more closely with the Chamber of Commerce to develop a plan to attract and retain those businesses here. We also have a Task Force that has been working all year brainstorming ideas to streamline our conditional use and zoning process so that new businesses can come to Orinda faster and with less red tape, and so that property owners in downtown Orinda can better redevelop older buildings so that we can realize more sales tax dollars. Of course, this doesn't happen in a vacuum; we appreciate the unflinching support of the Chamber of Commerce and the business community.

We have also enjoyed a stronger collaboration with community groups – like

the Chamber, the Orinda Arts Council, the Orinda Association, and Cal Shakes, and it has resulted in some great events like the "Shop Orinda" campaign, the "Orinda Salutes Cal Shakes" party at Theatre Square, and the wonderful donated art in our library plaza. These things all help to showcase our beautiful city as a great place to live and do business.

■ Infrastructure

My vision for Orinda is one in which our citizens have safe roads. Orinda's roads will require additional resources, including grant money, increased fees, redirecting funds within the city's budget, potential benefit assessment districts, and potential taxes. I am confident that we can build on the successful Moraga Way repaving project, which included \$1.7 million of state grants and which repaved 3.2 miles of what is one of the most heavily traveled roads in Orinda, and use it as a model going forward to fix the remainder of Orinda's roads. Roads are my first priority.

I am a strong advocate for walkways and bikeways, and I am very pleased that we are developing a master plan that will identify additional paths and lanes throughout Orinda. I will work to create a long-term plan for making Orinda a walking, pedestrian and bike friendly locale, including additional safe routes to school.

■ Three Areas of Need

Roads, roads, roads! The condition of our roads is not only a daily inconvenience to us, and an added cost of repair to our cars, but a safety issue, as the roads are used by fire fighters, paramedics and school buses. We know that we have a \$100 million problem, and we must secure financing in order to implement a comprehensive multi-year plan to rebuild Orinda's roads. I worked hard on the campaigns of both road measures, and I will use my experience on this issue to find a repair solution.

As well, we need to improve our downtown. We would all like to see additional

shops and restaurants, goods and services, available in the downtown, as well as housing to create a more lively environment. I will continue to work with the Chamber and business community to offer more to our residents.

The third priority for Orinda is to plan for the future of our great recreational

spaces. We must preserve our wonderful open space - over 1,000 acres in the Wilder/Gateway development alone – and I will work to find additional grant funding to help us create pathways and bikeways that will connect our outdoor spaces with our downtown and our neighborhoods and schools, including safe routes to schools.



**YOGA**  
**IYENGAR-ANUSARA METHOD**

• Strength • Stamina • Stress Reduction

**JEANNE DOWELL**

Former instructor under U.S. Olympic Committee Group classes Orinda, Moraga, and Mills College.  
 Private instruction available.  
**Ask about unique spa days!**  
 925.254.0193  
 www.yogawithjeanne.com

**FIRST CLASS FREE**



**鹿其 鹿麟 飯店**  
**SZECHWAN RESTAURANT**  
 CHINESE CUISINE

SZECHWAN - MANDARIN  
 LUNCH / DINNER / ORDERS TO GO  
**10% DISCOUNT ON TAKE-OUT ORDERS**  
 (Lunch Special Excluded)

Quality Food and Service  
 Serving Orinda Since 1980

Tues.-Thurs. 11:30 a.m. - 9:30 p.m.  
 Fri.-Sat. 11:30 a.m. - 10:00 p.m.  
 Sun. 4:00 - 9:30 p.m.  
 Closed Mondays

Tel 925 254-2020 • Fax 925 254-4098  
 79 Orinda Way • Orinda



**ANN SHARF**

When you need:

- a strong negotiator
- proven results for both buyers & sellers
- professionalism & service
- a top producer

Call ANN at (925) 253-2525;  
*she comes highly recommended...*  
 Website: www.annsharf.com  
 Email: ann@annsharf.com  
 93 Moraga Way, Orinda



**ORINDA CLEANERS**  
 First Class Quality Cleaning  
 with Fair Prices  
 EXPERT ALTERATIONS  
 37 Moraga Way • Orinda, CA 94563

7-6 Phone: 8:30-4  
 MON-FRI **254-5155** SAT

**All Fur Love Pet Care**  
 Loving your pets when you can't!

**(925) 212-7422**

- 🐾 Dogs, Cats, Birds and More..
- 🐾 Pet Visits
- 🐾 Mid-Day Dog Walks
- 🐾 Owner Operated/Orinda Resident
- 🐾 Bonded & Insured

[www.AllFurLovePetCare.com](http://www.AllFurLovePetCare.com)  
 Vet Recommended



**EFO - Educational Foundation of Orinda - wishes to thank its Business Partners for generously supporting the Orinda schools.**

**Return the favor. Do business with a partner!**

**November 28, 2008 - December 24, 2008**  
 Sun.-Thurs., 2pm - 8pm;  
 Fri.-Sat., 10am - 9pm

**3rd Annual Cabellon/Kang Christmas Tree Lot**  
<http://www.orindachristmastreelot.com>  
 old JFK University parking lot on Altarinda Road

**Portion of each sale to benefit EFO!**



**For more information, please visit**  
<http://www.orindaefo.org/businesspartners/BusinessPartnerList.html>

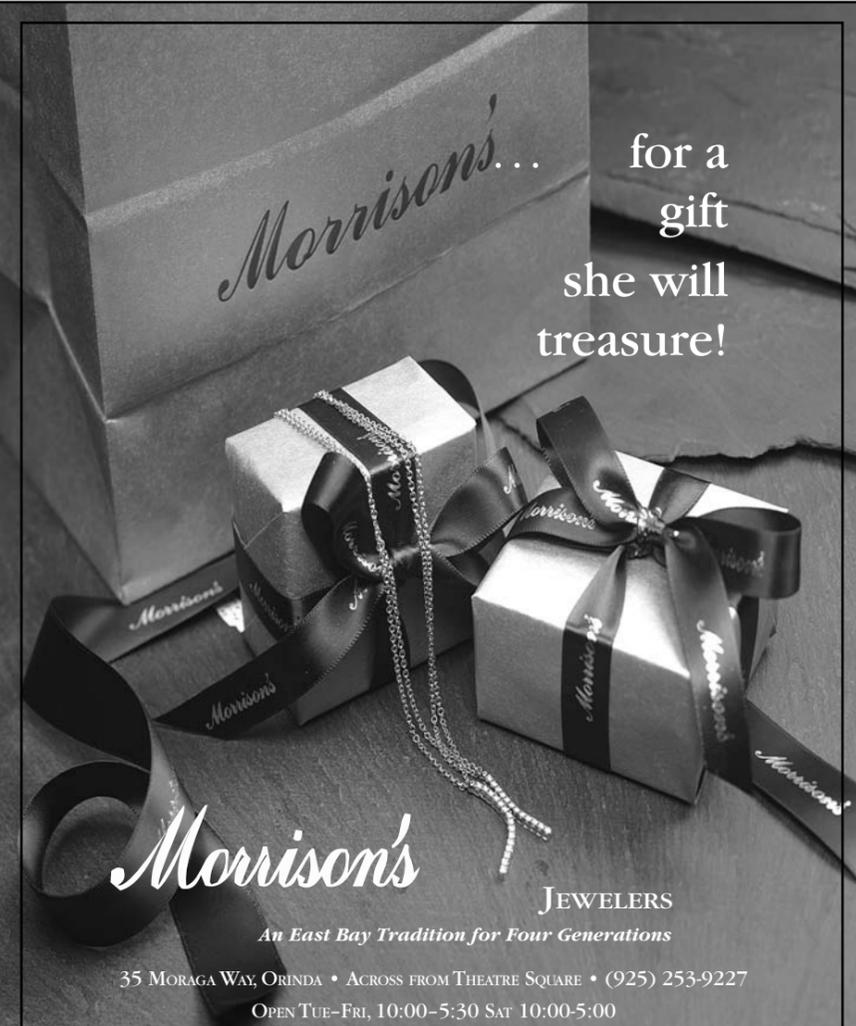

*Morrison's...* for a gift she will treasure!

**Morrison's**  
 JEWELERS  
 An East Bay Tradition for Four Generations

35 MORAGA WAY, ORINDA • ACROSS FROM THEATRE SQUARE • (925) 253-9227  
 OPEN TUE-FRI, 10:00-5:30 SAT 10:00-5:00

# Third Annual Orinda Christmas Tree Lot Benefits EFO

By GABRIELA CHAVET  
Contributing Writer

It's that time of year – Christmas tree time. The third annual Orinda Christmas Tree Lot will once again be held at 8 Altarinda, the old JFK University parking lot and the site of the new Pulte Homes project. Local residents and operators, Michael Kang and Barbara Cabellon, invite everyone to purchase their trees from the Orinda Tree Lot and help raise money to support local schools.

Kang, who is also a member of the Educational Foundation of Orinda (EFO) board, hopes to raise more awareness of the importance of EFO and all its supports. Since 1979, EFO has stepped in to help fill the state funding gap. Thanks to strong community-wide support, EFO has become a leader among K-12 educational nonprofits, setting the standard for fundraising and accountability. The Orinda Tree Lot contributed more than \$3,500 last year.

Kang and Cabellon have earned the reputation for having the freshest trees available. There will be fresh wreaths and garlands, fun stocking stuffers, and Matarador Marketplace students will be selling



CONTRIBUTED PHOTO  
Michael Kang and Barbara Cabellon will once again run the Orinda Christmas Tree Lot at 8 Altarinda Road with proceeds benefiting the Educational Foundation of Orinda.

products again.

The tree lot opens the day after Thanksgiving, November 28. The hours are Monday through Thursday, 2 p.m. to 8 p.m. and Friday through Sunday, 10 a.m. to 9 p.m. go to [www.orindachristmastreelot.com](http://www.orindachristmastreelot.com) or call Kang at 925-528-9522 for more information.

## Seasoned Shopper

Last Orinda Market This Season



BARBARA KOB SAR

The end of another successful farmers' market season in Orinda is in sight. On Saturday, November 15, the last tables will be folded and loaded onto trucks until next May's opening. Fortunately, I'll find many of these growers over at Sunday's year-round market in Walnut Creek, so my market basket is going to remain full of local fall and winter produce.

Stands filled with asparagus, strawberries and stone fruits are pleasant memories, but the looming cooler months promise me pomegranates, persimmons, sweet potatoes and a plethora of citrus.

It's also time to re-visit the world of winter squash. The next few months guarantee the best quality and widest selection of winter squash – all members of the cucurbit or gourd family.

Winter squash are allowed to ripen on the vine to develop their tell-tale hard shell. They shout diversity – color, shape, flavor and texture!

Vince and Penny Granberg from Rose Lane Farm in Brentwood arrive each week with some of the more unusual and fascinating heirloom varieties of winter squash. The large, white, pear-shaped Tennessee Sweet and the Australian Blue Jarradale catch my attention right away. Further perusing turns up the French *Musque de Provence*, a big beige deep lobed pumpkin, and the more common banana squash. Penny suggests cutting these large winter squash into halves or quarters to make them more manageable. Scoop out the seeds and place cut side down on a lightly oiled baking dish. Cover with foil and bake 300 – 325 degrees until tender (30 to 45 minutes). The flesh is then ready to scoop out to mash with a dab of butter and salt and pepper, toss into soups, pancake batter, risotto or pastas.

In addition to choosing a beautiful looking winter squash to spend some showtime on my kitchen counter, I choose the variety that best fits its purpose. The full, sweet flavor of buttercup squash makes them perfect candidates for pies, cakes and breads. The deep orange-colored flesh of the pear-shaped butternut squash (a result of the high carotene content) is naturally creamy and the smooth and the light-colored skin is easy to remove if necessary.

Appropriately named acorn squash look like large acorns with deeply ribbed sides. Green, white or gold in color, these squash

are simply cut in two to remove the seeds and baked with a little brown sugar and butter. I find acorn squash make a natural bowl to stuff with rice or sausage mixtures or applesauce. Just bake until almost tender, fill with desired mixture and continue baking until hot and tender. Other small sweet varieties include Kabocha (Japanese) and Delicata.

Other unique types from the winter squash family include Turban, Spaghetti and Opo. Turban squash are aptly named to describe a mottled green top that sits on a larger orange-colored base. Spaghetti or vegetable squash make a delicious pasta substitute. Once the squash is cooked, the



BARBARA KOB SAR  
A wide variety of winter squash will be seen at the November Farmers' Market.

flesh is removed using a fork to produce long, spaghetti like strands – kids love it.

Finding Opo squash is a snap when I visit the farmers' market. Opo squash range from 6 to 36 inches long, are oblong with a pale green skin and a firm, white flesh that contains seeds. When young, the Opo squash is ideal for sautéing or to use in soups and stews. As it grows larger and more bitter tasting, it's best used as a container (hence the alternate name "bottle gourd").

The best squash are heavy for their size and free of any soft spots. A dull shell tells me the squash was left on the vine long enough to completely ripen. I always choose one with a stem attached – as much for storage purposes as for its aesthetic appeal.

Baskets full of beautiful gourds (another member of the cucurbit family) in amazing shapes and colors are perfect for decorating holiday tables. They're inedible and extremely tough-shelled, but when all the flesh is removed, the shell can be dried and used as a container or utensil.

Enjoy, and see you at the market!

Barbara Kobsar can be reached at [cot-kitchen@aol.com](mailto:cot-kitchen@aol.com).

**KATTENBURG ARCHITECTS** **ORINDA**  
Fine Custom Homes and Additions 925 253 7828

[KattenburgArchitects.com](http://KattenburgArchitects.com) Van Ardenne Residence

## Orinda Sports and Family Chiropractic

**Chiropractic Care and Massage Therapy Supports School Sports**

Virginia Tech's football team's Head Coach Frank Beamer took the "Hokies" to a Big East Conference championship where they finished number 2 in the Associated Press. Some of the credit for their physical health and recovery from injuries is attributed to chiropractic care.

Junior quarterback Grant Noel feels that chiropractic gives him better flexibility and range of motion. "Just getting my back adjusted and loose helps with my trunk mobility as far as twisting and throwing."

With the success and testimonials of the football team, other athletes have also begun chiropractic. Mike Gentry, the assistant athletic director for athletic performance, summed it up by saying, "I see chiropractic as having two functions from my perspective. It helps our athletes return to competition faster if they have sustained some injuries, and secondly, it seems to be preventative, in the sense that it keeps our athletes more mobile and flexible and feeling better."

As more athletes discover the benefits of chiropractic care not only for injuries but additionally for increased performance, more athletes and teams are using chiropractic to gain an important edge.

**Call Dr. Jason Wong for a Chiropractic Sports Evaluation and Exam or Massage Therapy**

Appointments call (925) 258-0850  
96 Davis Road, Suite 3, Orinda, CA 94563  
[www.orindachiro.com](http://www.orindachiro.com)  
Most Health Insurances Accepted

A Hands-On Realtor Who Gets Her Homework Done

Earning High Marks For Client Satisfaction and Outstanding Performance

**MAUREEN WILBUR**  
Realtor

**For the 3R's of Real Estate**

- Relationships
- Resources, &
- Research

**Coldwell Banker**  
Orinda, CA 94563

925-253-6311 VM  
[Maureen@MaureenWilbur.com](mailto:Maureen@MaureenWilbur.com)  
[www.MaureenWilbur.com](http://www.MaureenWilbur.com)

## PRESCHOOLS

## Lamorinda Preschools Offer Fun, Learning and Lots of Activities

Many mothers and fathers welcome the time that a child is old enough to go to preschool, allowing a breather in tight schedules. Here is *The Orinda News'* list of area schools, including preschool, tot drops, and pre- and post-school experiences. Pull out this section and keep it on hand for last-minute needs, or to plan your upcoming months.

Most of the schools listed below have websites or an email address that will offer full descriptions of the programs, costs and enrollment information, as well as wait-list forms, if needed.

The website [www.eastbaypreschools.com](http://www.eastbaypreschools.com) (and the site used primarily by some of the schools below) is another good destination for more information.

**Orinda****Fountainhead Montessori School**

30 Santa Maria Way, Orinda, CA 94563  
925-820-1343  
7 a.m. – 6 p.m.

Prep/Toddler, Preschool, PreK, Kindergarten, Childcare (hourly), Summer School  
[www.fountainheadmontessori.org](http://www.fountainheadmontessori.org)

**Holy Shepherd Christian Preschool**

433 Moraga Way, Orinda, CA 94563  
254-3429  
9 a.m. – noon, with extended day till 2 p.m.  
Toddler (age 2-3), Pre-kindergarten (ages 4-5)

Extended care to 2:00 p.m. (monthly or hourly)  
[www.holyshepherd.org](http://www.holyshepherd.org)



SALLY HOGARTY

Eamon McEneaney and Zach Moudi enjoy the cars at Lafayette's Tot Drop.

**St. John Preschool**

501 Moraga Way, Orinda, CA 94563  
254-4470  
7 a.m. – 5:30 p.m.  
Preschool (ages 2-3 or 4-5), Jr. Kindergarten (ages 4+)  
[preschool@stjohnorinda.org](mailto:preschool@stjohnorinda.org)

**St. Mark's Nursery School**

451 Moraga Way, Orinda, CA 94563  
254-1364  
9 a.m. to 2 p.m. Monday to Friday  
Age 3 (Tu/Th), age 4 (Mon/Wed/Fri)  
Lunch Bunch (Daily to 2 p.m., all ages)

**St. Stephen's Nursery School**

66 St. Stephen's Dr., Orinda, CA 94563  
254-3770, ext. 19  
9 a.m. – noon, Tuesday and Thursday, for 2-year-olds  
9 a.m. to noon Monday, Wednesday, Friday for 3- to 4-year olds, with optional lunch bunch until 2 p.m.  
[www.ststephenorinda.org](http://www.ststephenorinda.org)

**The Orinda Preschool – TOPS**

10 Irwin Way, Orinda, CA 94563  
254-2551  
8:45 a.m. – 2:30 p.m.  
Preschool (ages 2-4), Lunch Bunch, Playgroup (ages 3-5), Developmental kindergarten (age 5)  
[www.topsonline.org](http://www.topsonline.org)  
[topsonline@sbglobal.net](mailto:topsonline@sbglobal.net)

**Lafayette****Center of Arts, Technology & Science**

961 1st St, Lafayette, CA 94549  
925-283-4500  
7 a.m. to 6 p.m.  
Before/after school care only for school-age children only

**Child Day School**

1049 Stuart St., Lafayette, CA 94549  
925-284-7092  
[www.tcdschools.com](http://www.tcdschools.com)  
Ages 2 to 6, minimum 3-5 days per week  
6:45 a.m. to 6:15 p.m.  
Infant/Toddler (age 1-plus), Twos, Threes, Pre-K, summer care, Developmental kindergarten  
[www.tcdschools.com](http://www.tcdschools.com)

**Diablo Valley Montessori School**

3390 Deerhill Road, Lafayette, CA 94549  
925-283-6036  
8 a.m. to 5 p.m.  
Infant/toddler (ages 3 months to 2 years), Two's/Transition (2 – 3.5), Preschool/Kindergarten (3-6) with times available 7:30 a.m. to 6 p.m.



SALLY HOGARTY

Students in **Saint Mark's** new pre-kindergarten class have fun learning the skills they will need next year in school.

Extended Care (7:45 am – 6 pm for enrolled students)  
Summer Program (age 3-6)  
[www.dvms.org](http://www.dvms.org)

**First Steps Learning Center**

3201 Stanley Blvd. Lafayette, CA 94549,  
925-933-6283  
Ages 0-2; infant care  
Full time only, year-round

**French for Fun**

3468 Mt. Diablo Blvd., Suite B100, Lafayette, CA 94549  
925-283-9822

Usually applications are submitted in spring for fall sessions, but openings sometimes occur during the year.

Age 2-5+, Toddler, Preschool, Pre-K, Kindergarten  
[madame@frenchforfun.com](mailto:madame@frenchforfun.com)

**Gan Ilan Preschool, Temple Isaiah**

3800 Mt. Diablo Blvd., Lafayette, CA 94549  
925-284-8453  
9 a.m. to 1 p.m.: Ages 2-5  
8 a.m. to 5 p.m., Extended Care  
[ganilan@yahoo.com](mailto:ganilan@yahoo.com)

[SEE LAFAYETTE page 12]



- Pet Sitting
- Dog Walking
- Pet Taxi
- Home Watch/Security,
- Collect Mail and Newspapers
- Water Plants
- Insured and Bonded

**Office 925-254-3677**  
**Cell 925-368-8978**  
[animal-house@comcast.net](mailto:animal-house@comcast.net)

**Fall or Winter Travel Plans?**

Let us take the worry out of what to do with your home and pets while you are away.

## College Preparatory starts in Kindergarten.

The  
**Dorris-Eaton  
School**

Independent • College Preparatory  
Elementary • Junior High • Preschool  
Walnut Creek • Alamo  
Since 1954

*The difference is education.®*

[dorriseaton.com](http://dorriseaton.com)

925.933.5225

gratitude brings blessings

Come share  
your gratitude  
to God!

THANKSGIVING DAY SERVICE  
Thursday, November 27, 10 AM - 11 AM

Hymns • Scripture Readings  
Grateful Sharing  
No Collection • Children Welcome

**Christian Science Church**

24 Orinda Way (next to the Orinda Library)  
Walk from Orinda BART

254-4212

PRESCHOOLS

◆ LAFAYETTE from page 11

**Happy Days Learning Center**  
3205 Stanley Blvd., Lafayette, CA 94549  
925-932-8088  
7 a.m. to 6 p.m.  
Age 2-5-plus, Pre-school, Kindergarten  
Age 5-12, Before and after school care

**Husky House Club**  
3855 Happy Valley Road, Lafayette, CA 94549  
925-283-7100  
7:30 a.m. to 6 p.m.  
Ages 4.9 to 12 yr  
Before and after school program/Summer

Camp  
www.Huskyhouseforkids.org

**Joyful Beginnings Preschool**  
955 Moraga Rd., Lafayette, CA 94549  
925-284-1143  
8:45 a.m. to 2:45 p.m.  
Preschool and Pre-kindergarten age 2.7-6  
Lunch Bunch (hourly)  
joyfulbeginnings@sbcglobal.net

**Merriewood Children's Center**  
561 Merriewood Dr., Lafayette, CA 94549  
925-284-2121  
Toddler-parent class, Monday only



SALLY HOGARTY

Van Butler (L) and Eli Brent enjoy a game of ball at Joyful Beginnings' outdoor play area.

Preschool: age 2-3 (2 day), age 3-4 (3 day) 8:30 a.m. to 2:15 p.m.  
Ages 4 and 5 (4 or 5 days), 9 – 11:30 a.m.; extended care available  
www.Merriewood.org

**Old Firehouse School**  
984 Moraga Road, Lafayette, CA 94549  
925-284-4321  
8 a.m. to 5:30 p.m.  
Infants to Prekindergarten (4 months to age 5)

**Seedlings**  
Lafayette-Orinda Presbyterian Church  
49 Knox Dr., Lafayette, CA 94549

**Michael Lane Preschool**  
682 Michael Lane, Lafayette, CA 94549  
925-284-7244  
9 a.m. to 12 noon  
Lunch 12 noon to 1 p.m.  
Mixed age group, (2.9-5.6 yr)  
stanselmshpreschool@mail.com

**Tot Drop – Preschool by Appointment**  
500 St. Mary's Road, Lafayette, CA 94549  
925-284-3999  
9 a.m. to 1 p.m.  
Ages 1-5, pay as you go  
Maximum 12 hrs/wk  
www.totdrop.com

**White Pony**  
A division of the Meher Schools  
999 Leland Dr., Lafayette, CA 94549  
925-938-9958  
7 a.m. to 6:30 p.m.  
Preschool, Pre-K, Kindergarten (also grades 1-5)  
www.meherschools.org

**Moraga Child Day School**  
372 Park St., Moraga, CA 94556  
925-376-5110  
6:45 a.m. to 6:15 p.m.  
Infant/Toddler (age 1-plus), Ages 2-3, Pre-K, Summer care, developmental kindergarten  
www.tcdschools.com



Dentistry with a woman's touch.

**Mary H. Smith, D.D.S.**  
•  
**Cecelia Thomas, D.D.S.**  
925.254.0824

General dentistry done with a cosmetic emphasis to improve and enhance natural looking smiles. Our staff has many years of experience and training to take care of all of your dental needs. • Adults, Children, Nitrous Oxide, Implant Dentistry, Cosmetic Dentistry, Invisalign Certified • Complimentary Consultations

Independent Living in a More Supportive Environment

Meet Roger – He'll Take You Safely All Over Town

Transportation is a hot issue these days. Are you looking for a safe, convenient, inexpensive and energy-saving way to get around town? One way Byron Park residents save money and lower their stress levels is to take the Byron Park buses for shopping, medical appointments, and recreational outings. A familiar sight all over town, our two buses are free for all Byron Park residents, and depart six times a day, making round trips and pick-ups throughout the day.

Door-to-Door Service: Byron Park buses pick you up at the front door, drop you off at your place of business, and bring you back home when you're ready for a return trip... No parking hassles, no gas tanks to fill, no worry about wending your way through Walnut Creek traffic.

The medical bus runs Monday through Friday. The Shopping/Recreational bus operates seven days a week.



Retirement Residence

Please call for information, brochure, or tour.

925.937.1700

800.937.7974

www.byronpark.com

"An AF Evans Senior Community"  
Lic. #071440784



- Fine dining: Choose one, two, or three meals a day
- Free transportation
- Weekly housekeeping included
- Kitchens in every apartment
- Free linen service
- Month-to-month rentals
- Assisted Living services available

1700 Tice Valley Blvd. • Walnut Creek, CA 94595



SALLY HOGARTY

The storyteller at St. Marks Preschool has these youngsters' undivided attention.

925-284-3870  
www.lopc.org  
9:15 a.m. to 2:15 p.m.  
Infant/toddler, Preschool, Pre-K (ages 4 by 12/1)  
Extended care, ages 2-4

**Springhill Kids Hideout**  
3301 Springhill Rd., Lafayette, CA 94549  
925-283-7808  
7 a.m. to 6 p.m.

**Creative Playhouse**  
1350 Moraga Way, Moraga, CA 94556  
925-377-8314  
7 a.m. to 6 p.m.  
Young Preschool (2-3), Preschool (3-4), Pre-K (4-5)  
Minimum 3 days per week

**Fountainhead Montessori School**  
1450 Moraga Rd., Moraga, CA 94556  
925-820-1343

[SEE MORAGA page 13]

**Bottomley Farm**  
Lessons and Training for Children and Adults.

Sign up for Winter Workshops and Winter Semester Classes Now.  
dressage 🐾 horsemanship lessons 🐾 training 🐾 boarding

10 minutes from Lamorinda

bottomleyfarm.com

1131 Bear Creek Road

925.228.3766

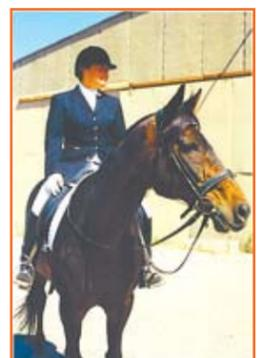

PRESCHOOLS



SALLY HOGARTY

Madison Jones plays in the new play structure at **TOPS** in Orinda.

◆ MORAGA from page 12

7 a.m. to 6 p.m.  
Prep/toddler (2-3), Preschool (3-5), Pre-K/  
Kindergarten (4-6)  
Child care (2-6) hourly  
www.fountainheadmontessori.org

**Growing Tree Preschool**

1695 Canyon Rd., Moraga, CA 94556  
925-376-8280  
8 a.m. to 4 p.m.  
Tots (age 1.6+), Two's, Three's, Pre-K  
(4-5), Transitional kindergarten (4.11-6)

**Moraga Bright Beginnings Christian Preschool**

1689 School St., Moraga, CA 94556  
925-376-2600  
9 a.m. to 12 noon Preschool, 12 noon to 3  
p.m. extended day  
Three's (Age 2.6-3.8), Pre-kindergarten  
(3.9 to 4.1), Developmental kindergarten  
(4.9 - 5.5)  
www.eastbaypreschools.com

**Moraga Valley Presbyterian Church Nursery Preschool**

10 Moraga Valley Ln., Moraga, CA 94556  
925-376-4800 ext. 248  
9 a.m. to 12 noon Preschool (age 2 by De-  
cember 1) to Pre-K (age 5 by March 1)  
12 noon to 3 p.m. Extended care  
www.Mypctoday.org

**Mulberry Tree Preschool**

1455 St. Mary's Rd., Moraga, CA 94556  
925-376-1751  
8:30 a.m. to 4 p.m.  
Variable schedule, age 2.5 to 5  
Extended care available (hourly),  
5 days/wk  
mulberrytreepreschool@yahoo.com

**Saklan Valley School**

1678 School St., Moraga, CA 94556  
925-376-7900  
7 a.m. to 6 p.m., Extended Day  
Preschool (age 2.9-4), Junior K (age 4-5)  
www.saklan.org



SALLY HOGARTY

These youngsters are obviously having fun playing a circle game at **Holy Shepherd Preschool** on Moraga Way in Orinda.

**COLDWELL BANKER**

*In Patti's world,  
everyone's a winner!*



**Patti Camras**  
Real Estate Services  
5 Moraga Way  
Orinda, CA 94563  
(925) 253-4609  
patti.camras@camoves.com  
www.patticamras.com



PRESCHOOL ON DEMAND!  
**TOT DROP**

*"Only Come When You Want.  
Only Pay When You Come."*

**YOU** make your own schedule. WEEKDAYS 9am - 1pm  
As little as 1 hour or up to 12 hrs/wk. **\$9/hr.**  
**YOU** set your days and arrival & YOUR pick up times.  
Come occasionally or weekly spots are available.  
**FREE** cancellation when your plans change.

**DIAPER WEARERS WELCOME!**  
NEW STUDENTS MAY ENROLL AT ANYTIME.

Call to get started  
**925-284-3999**

**COUPON**  
1 **FREE** hr.  
\$9 value  
New families only

Open **YEAR ROUND !**

**Lafayette, Walnut Creek, Pleasant Hill  
Benicia, Hercules, Pleasanton, Livermore**  
**www.totdrop.com**

**HIRING:**

kind, fun, gentle, easy going, high energy adults  
who love kids, noisy play, & messy projects.  
Work 2-5 mornings/wk. **No ECE REQ'D.**  
**WORK WITH YOUR TODDLER AT YOUR SIDE.**



Kristin Walker M.D., Inc.  
General & Cosmetic Dermatologist  
89 Davis Road, Suite #180  
Orinda  
(925) 254-1080

Dr. Walker, board certified dermatologist, offers care in general adult and pediatric dermatology, laser surgery, skin cancer surgery, and cosmetic dermatology. Her friendly and supportive staff can assist you with diminishing the effects of nature to reveal the real you underneath. Dr. Walker and her caring staff can help return the glow to your skin with the most advanced skin care lasers and technologies. Dr. Walker is proud to announce the addition of a Nutritionist and Aesthetician to her practice.

NEW ADDITIONS TO THE OFFICE:  
IPL-Photo Genesis Rejuvenation Treatment for Rosacea, Sun Damage, Fine Lines  
Laser Hair Removal  
Microdermabrasion  
Waxing

COSMETIC PROCEDURES AVAILABLE:  
Botox Cosmetic Restylane Sclerotherapy  
Collagen Peels

AVAILABLE SKIN RESTORATION SYSTEMS:  
Procyte Jan Marini  
MD Forte Glyquin

ITCH TO STITCH

# Itch to Stitch

## Elegant Holiday Table Linens

Doreen Leong



In this month's sewing project, we have mixed rustic linen with rich satin and velvet ribbons to create a sophisticated and casually elegant table setting for the holidays.

**Basic sewing supply list**

- Coordinating thread
- Yardstick
- Fabric marker
- Scissors
- Sewing machine
- Large flat surface for cutting and ironing
- Iron
- Fusible web tape
- Straight pins

**Additional notes**

- All seam allowances are 3/4" wide unless otherwise stated.
- All cutting measurements include the 3/4" seam allowance.
- Before turning the placemats and table runner inside out, trim seam allowance for a clean finish.

**4 Placemats – each 14" wide x 21" long**

**Fabrics and ribbon:**  
 2 yards of 54" wide solid fabric  
 4 yards of 3" wide satin ribbon  
 4 yards of 1" wide velvet ribbon  
 2 yards of a stiff interfacing such as Timtex – should be washable

**Step 1. Cut the pieces.**

- Cut 8 pieces of solid fabric at 15-1/2" wide x 22-1/2" long.
- Cut 8 lengths of 3" wide satin ribbon at 16" long.
- Cut 8 lengths of 1" velvet ribbon at 16" long. Note that velvet should not be ironed directly; this will scorch and flatten the velvet nap. Iron on the back side or with a pressing cloth covering the velvet before ironing.
- Cut 4 pieces of interfacing at 15-1/2" wide x 22-1/2" long.

**Step 2. Preparing and sewing the ribbon to the top side of the placemat.**

- Mark the top side of the placemats with a fabric marker for placement of the ribbons—Figure A.



CONTRIBUTED PHOTO

Make beautiful table settings for your holidays this year.

- Line up the ribbons over the marks and either pin or use fusible web tape to secure the ribbons before stitching. Carefully machine top stitch or hand stitch ribbons into place. Iron the backside of the placemat and trim any ribbons that are not aligned with the edges of the table runner.

**Step 3. Pin the interfacing onto the wrong side of the top of the placemat and sew a 1/2" seam all around 4 sides.**

**Step 4. Sewing the back and front sides together**

- With the right sides together, pin the front and back sides of the placemats together aligning all edges.
- Sew a 3/4" seam around all 4 sides but leave a 5" opening at the bottom edge.
- Trim the 3/4" seam down to 1/4" all around but leaving the 3/4" seam allowance at the 5" opening. Turn the placemat inside out and pull through the 5" opening. Carefully iron and hand sew the 5" opening closed.

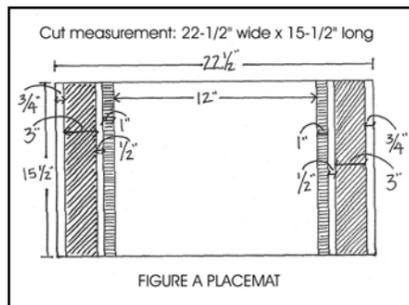

FIGURE A PLACEMAT

[SEE STITCH page 16]

**Independence. Dignity. Affordability.**  
 We can ensure that you or your loved ones are able to enjoy the comforts of home for years to come!

**Services tailored to your needs:**

- Companionship • Bathing & Grooming Assistance • Light Housekeeping
- Meal Prep & Clean Up • Medication Reminders • Walking Assistance
- Alzheimer's & Dementia Care • Laundry & Linen Changing
- Errands & Transportation • Up to 24-hour Care
- Licensed, Insured & Bonded, RN Supervised

CALL TODAY FOR YOUR FREE ASSESSMENT  
**(925) 376-8000** Serving the Lamorinda Community  
 1100 Moraga Way

**Senior Helpers**  
 Caring In-Home Companions

[www.seniorhelpers.com](http://www.seniorhelpers.com)

**At the UC Eye Center seeing is believing.**

At the UC Eye Center in Berkeley, how you see is what you get. Because we're part of the top-rated UC School of Optometry, we're here for you and your family in a whole range of ways:

- Pediatric Vision Care • Eye Examinations
- Lasik Surgery • Geriatric Vision Care • Contact Lenses
- Eyewear Center • Specialized Vision Care

Make an appointment and go Blue!

Open to the Public 7 Days a week [www.caleyecare.com](http://www.caleyecare.com) 510.642.2020  
 Free parking with appointments. Walk over or use our free shuttle!

**real experiences**

**MAGGIE**  
 Margaret, an avid cyclist, suffered extensive injuries when hit by a car. After several surgeries, she transferred to our care and received intensive medical and rehabilitation services to help regain her ability to care for herself. Margaret is now back home.

**ROGER**  
 Roger had a double knee replacement. After the surgery, he needed physical rehabilitation before returning home. We helped him regain strength and endurance. Roger is home and golfing with his friends and family.

ManorCare Health Services - Tice Valley  
 1975 Tice Valley Blvd., Walnut Creek, CA 94595  
**925-906-0200**

ManorCare Health Services - Walnut Creek  
 1226 Rossmoor Parkway, Walnut Creek, CA 94595  
**925-975-5000**

- Post-hospital acute care
- Rehabilitation therapies
- Skilled nursing

**ManorCare** Health Services

## WOMENSING

## WomenSing Gives New Composers a Voice

■ Work by two Miramonte grads to be performed June 3

By ELANA O'LOSKEY  
Staff Writer

Imagine a bright, young choral composer inspired by the poetry of a school-age writer who, in turn, is inspired to study the environment – specifically, Bay Area watersheds. Put them together under the guidance of a nationally recognized American composer and mentor and *voila* -- a unique choral experience!

That's what WomenSing is all about – unique choral experiences. To that end, the Lamorinda choral group has partnered with River of Words in Berkeley to offer young composers the opportunity to create new choral music in a project dubbed Youth Inspiring Youth. Mentored by composer Libby Larsen, the juried project lasts three years. Compositions will be based on inspiring children's poetry from the River of Words (ROW) project.

WomenSing has commissioned two Miramonte High School graduates, Jack Henry and Ryan Harper, to compose the initial compositions. Their work will premiere at a concert entitled "The Blue Eye of God" on June 3 at Miramonte High School and on June 7 at the First Congregational Church in Berkeley. Henry now studies composition at Diablo Valley College while Harper is a sophomore composition major at Yale University. Henry and Harper's participation spans the first year of the project. The second and third years will include yearly regional juried competitions to choose two composers between the ages of 18 and 25 to write new treble choral works, utilizing the nature-inspired children's poetry.

When asked what this commission meant to him, Henry replied: "I'm extremely excited to be collaborating with WomenSing, Ms. Larsen, and my comrade Ryan for this

*"I'm really looking forward to working with two such wonderful choirs," says Ryan Harper. "My piece 'Wit and Fright' features both WomenSing and the Piedmont Choir."*

commission, which I am sure will inspire young composers to do the same. Word to the wise – to any young composer – start early, get exposed to a lot of different music. I'm just trying to do my part to contribute to the awesome world that expresses the inexpressible - music."

Harper feels WomenSing's three-year Youth Inspiring Youth project provides an

important head start for young composers in a meaningful way. "I'm really looking forward to working with two such wonderful choirs. My piece 'Wit and Fright' features both WomenSing and Piedmont Choir," he explains. "WomenSing's initiative to commission pieces from young composers featuring poems from the River of Words project is a fantastic way to promote artistic collaboration among young people. It is projects like these that really help young composers find an individual voice."

In 2007, Patty Murray happened upon the ROW gallery, Young at Art, at 933 Parker Street, No. 38, in Berkeley. When she learned that Chris Brubeck had used ROW poetry to create "River of Song," a libretto of five songs included in his CD, *Convergence*, sung by Frederica von Strade, the idea for the Youth Inspiring Youth project began to take root.

Founded by former U.S. Poet Laureate and 2008 Winner of the Pulitzer Prize Robert Haas and writer Pamela Michael in 1995, ROW has been conducting training workshops for teachers, park naturalists,



LYNDA LEONARD  
Composer Libby Larsen works with the young composers.

grassroots groups, state resource agencies, librarians and others.

Extraordinary works have been submitted to their world-famous, free, annual environmental poetry and art competition conducted in affiliation with The Library of Congress Center for the Book. The contest theme is watersheds, a meaningful, scalable way of looking at the whole of nature. They accept poems in English, Spanish and American Sign Language (on videotape). For more information on ROW, go online to [www.riverofwords.org](http://www.riverofwords.org) or call

510-548-POEM.

WomenSing, which began in 1965 as the Orinda Women's Chorale, now boasts 55 members from the San Francisco Bay Area. Singers range in age from 23 to 70 and perform sacred, secular and gospel choral works from September to June. WomenSing will release its first licensed CD this winter entitled *Songs of Innocence and Experience*. An original painting by Jules

*"I'm just trying to do my part to contribute to the awesome world that expresses the inexpressible – music," says Jack Henry.*

Campbell (current WomenSing member) and Edward Maravilla inspired the cover. You may find it at [www.womensing.org](http://www.womensing.org) or on [www.amazon.com](http://www.amazon.com).

The group's holiday concert, O Holy Night!, explores a galaxy of seasonal music including titles from the new CD with a special guest appearance by mezzo-soprano Jessica Dearthoff on December 7 at the First Congregational Church in Berkeley and on December 10 at the Lafayette/Orinda Presbyterian Church. Contact

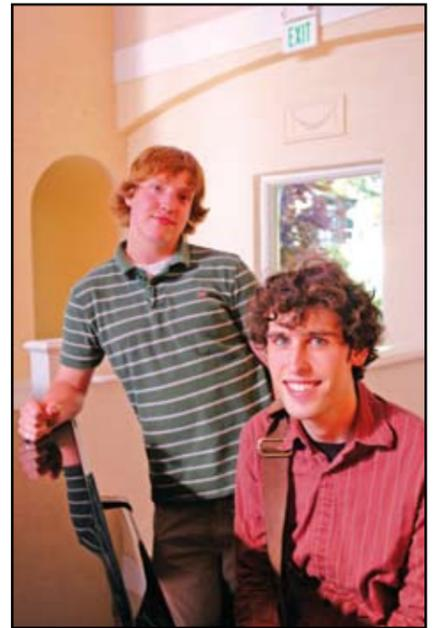

LYNDA LEONARD  
Composers Jack Henry (L) and Ryan Harper will premiere their new works at WomenSing's June 3 concert.

them by phone at 925-974-9169 for more information.

Women interested in auditioning for WomenSing should call 925-974-9169 or email [info@womensing.org](mailto:info@womensing.org).

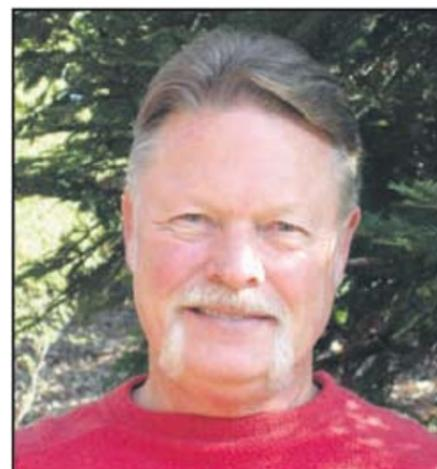

### Residential and Restoration Painting Services

Meticulous attention to detail  
37 years of satisfied customers

David Collins, Orinda

925-254-6882



## Orinda Shell Auto Care

- Complete Auto Care -  
Scheduled Maintenance - Air Conditioning - Brakes and Suspension  
- Electrical Repairs - Warranty Repair  
- Smog Inspection - Wheel Alignments  
- Senior Discount - Free shuttle service -  
Walking distance from BART

Celebrating Over 9 Years in Business  
Thank You Orinda!



Kathy Mitchell Owners Joey O'Brien  
925 254-1486 • fax 925 254-8375

9 Orinda Way  
e-mail [orindashell@aol.com](mailto:orindashell@aol.com)



# BLUE RIDGE

## LANDSCAPE Co.

Lic# 818633

Blue Jay Feldman

OWNER/OPERATOR  
[WWW.BLUERIDGELC.COM](http://WWW.BLUERIDGELC.COM)

DESIGN  
INSTALLATION  
IRRIGATION  
DRAINAGE  
STONEMWORK  
CONCRETE WORK  
DECKS  
FENCES  
PATIOS  
LAWNS  
PONDS  
& CLEANUP  
HAULING  
COMMERCIAL  
MAINTENANCE

LICENSED  
INSURED

ORINDA  
RESIDENT

# 925-258-9233

CONTINUATIONS

◆ **STITCH** from page 14

**Table runner – 18" wide x 72" long**

- Fabrics and ribbon trim:
- 2 -1/4 yards of 54" wide solid fabric
- 5-1/2 yards of 1-1/2" wide satin ribbon
- 1-1/4 yards of 1" wide velvet ribbon
- 2 -1/4 yards of a stiff interfacing such as Timtex – should be washable

**Step 1. Cut your pieces**

- Cut 2 pieces of fabric at 19-1/2" wide x 73-1/2" long
- Cut 2 lengths of 1-1/2" wide satin ribbon at 74" long
- Cut 2 lengths of 1-1/2" wide satin ribbon at 20" long
- Cut 2 lengths of 1" wide velvet ribbon at 20" long. Note that velvet should not be ironed directly; this will scorch and flatten the velvet nap. Iron on the back side or with a pressing cloth covering the velvet before ironing.
- Cut 1 piece of interfacing at 19-

1/2" wide x 73-1/2" long

**Step 2. Preparing and sewing the ribbon to the top side of the table runner**

- Mark the top side of the table runner with a fabric marker for placement of the ribbons (Figure B)
- Line up the ribbons over the marks and either pin or use fusible web tape to secure the ribbons before stitching. Carefully machine top stitch or hand stitch ribbons into place. Iron the backside of the table runner and trim any ribbons that are not aligned with the edges of the table runner.

**Step 3. Pin the interfacing onto the wrong side of the top of the table runner and sew a 1/2" seam all around 4 sides.**

**Step 4. Sewing the back and front sides together**

- With the right sides together, pin the front and back sides together aligning all edges.
- Sew a 3/4" seam around all 4 sides but leave an 8" opening at the bottom edge.

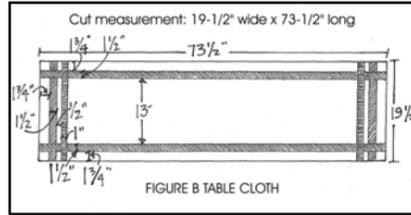

- Trim the 3/4" seam down to 1/4" all around but leaving the 3/4" seam allowance at the 8" opening. Turn the table runner inside out and pull through the 8" opening. Carefully iron and hand sew the 8" opening closed.

**4 Dinner Napkins – each 22" wide x 22" long**

- Fabrics
- 3 yards of 54" wide solid fabric

**Step 1. Cut 4 pieces of fabric at 26" wide x 26" long**

**Step 2. Finishing the edges (Figure C).**  
On the wrong side of the fabric, fold the

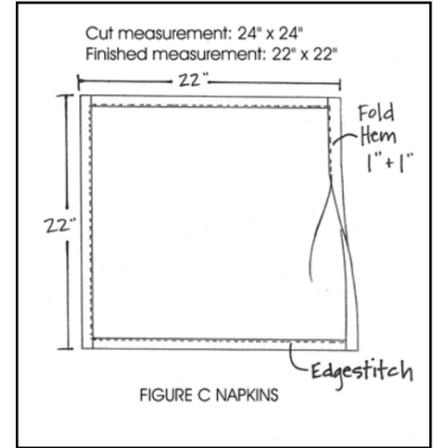

raw edges 1" on all 4 sides, iron. Then turn the folded edges in again 1" on all sides, iron. Carefully topstitch or hand stitch the 1" hem all around the napkin, iron again.

\*Use a contrast thread color for the topstitching for an interesting design detail.

Leong can be reached at doreen@leonginteriors.com.

Are you considering buying or selling your home? Do you want to know what your home is worth in the current market? Are you wondering what is happening to home prices in the area? Give me a call about your real estate needs.

**Leila Schlein**  
**925-899-7927**  
 51 Moraga Way, Orinda  
 Leila.Schlein@PruRealty.com  
 www.LeilaSchlein.com

**GET THE SERVICE YOU DESERVE...**

Directors Kim Winter and Janet McGill

**TOTAL CLEAN**  
HOUSE CLEANING SERVICE

**Our Money Back Guarantee**  
*If for any reason you are not happy with our work, we will reclean the area for free. And if you are still not pleased, you pay nothing.*

**Protecting You and Your Home Since 1985**  
 Our employees are insured and bonded. Social Security and Workers' Compensation is paid and we assume absolutely all liability for our employees.  
**Top Quality Customer Service**  
 We meet with each of our new clients, and we take the time to review each home and each customer's needs. **Total Clean** was recently rated "Top Quality" by a Bay Area Consumer Group, and we are dedicated to providing the highest quality of service possible.

*A clean house is just a phone call away. 376-1004*

**Christmas Trees**  
**Wreaths & Garlands**  
**Ornaments & Gifts**  
*will be available*  
*at Thanksgiving time*

**Free Local Delivery**

**McDonnell Nursery**  
 Moraga Way • Orinda • **254-3713** 196  
 – Open Daily –

◆ **BACKYARD** from page 2

wood fires.

On visits to sparsely furnished school classrooms, we observed information posters about HIV/AIDS. Botswana has the highest rate of infection in the world, where it is estimated that 36 percent of the population between the ages of 15 and 40 are infected. Interestingly, Botswana has a stable government, no wars, and an 80 percent literacy rate.

While all four countries are desperately poor, Zimbabwe appeared to be the worst, with their economy in shambles. Stores have few household goods to sell. In Victoria Falls, residents walk across the bridge into Zambia, continuing to the nearest town 10 miles farther, to purchase food to carry home. On August 18, CNN reported Botswana's inflation rate at 11.2 million percent, with a loaf of bread costing 1.6 billion Zimbabwe dollars. Such figures are incomprehensible.

Victoria Falls does offer good shopping for tourists, with its panoply of craft sellers. It's also home to the beautiful falls, claimed to be the world's largest at a mile wide and 360 feet in height.

Cape Town, our last stop, is beautifully situated on a bay with the massive Table Mountain as its background. It's a cosmopolitan city with a bustling waterfront. The tour to Robben Island where Nelson Mandela was imprisoned for 27 years was sobering. A growing wine industry makes for a pleasant journey through vineyards to Stellenbosch where buildings have a lovely Dutch influence. Another day, traveling

along the coast to the Cape of Good Hope, we added a new animal to our list: African penguins.

Throughout the trip, OAT provided opportunities to meet the African people. We learned more about their history, culture and current conditions. At the schools in the bush, we talked with college-educated teachers who lived in housing around the campuses, in the same simple homes as the villagers, with no modern conveniences. During a home-hosted dinner, a frank-talking woman named Norma, said, "We're still caught in the middle and discriminated against, but now the blacks are at the top and the whites at the bottom."

We found male-dominated cultures in all the countries visited. Our main guide, Mandla, explained, "Because it's still the custom for the groom to pay for the bride with cows, he feels he owns her, and she must do his bidding. Even though I trained as a chef, I would be ridiculed if I cooked at home, but I consider our culture repressive. Things are changing for women, which I regard as progress." We visited his home, which had all the modern conveniences – quite a contrast to the simple village life in which he was raised.

As to another comparison of their ways to ours, Salwah, another guide, presented this analogy: "Our television is the fireside. Each one, sitting around it telling stories, is a channel. We can have 20 or 30 channels on our TV, and it's free." Certainly, many things in various African cultures should change, but adopting some of their simpler lifestyles could be beneficial if we adopted them into the American one.

**LAMORINDA**

**CONTRACTOR**

- Kitchen & Bathroom Remodeling
- Decks
- Room Additions
- Hardwood Floors
- Door & Window Replacement
- Tankless Water Heaters Installation
- And More

**JAD Construction is a Lamorinda based company.**  
**Family owned and operated with over 20 years experience**

Home office: (925) 254-4080 • Mobile: (925) 286-8685  
 Email: Lamorinda contractor @ gmail.com  
 Licence #598907

## HELPING AIDS VICTIMS

## Local Photographer Uses Talents to Help Women in Africa With AIDS

By **BOBBIE DODSON**  
Staff Writer

In Malawi, Africa, the life expectancy is 36 years, largely because of HIV/AIDS. Now Caroline Lovell, a professor at John F. Kennedy (JFK), wants to make a difference in especially the lives of women affected with the virus. Next August, she will travel to this small, impoverished nation to take portraits of some of these women, and their children, in order to document and preserve family legacy.

"Malawi has an oral culture. Most women lack even pencils and paper, so their stories will not be written and remembered unless someone helps. As a photographer, I can give them visual memories to pass on from one generation to the next," Lovell says. "It will also help these women to know that women outside of Malawi care and support them. It helps to know others are interested in their culture and needs."

This project, Voice Flame Writers - Malawi, was born after fellow JFK professor Mary Tuchscherer visited Malawi. In talking with the HIV-positive women there,

portraits of HIV-positive women and their children, then creating photographic albums with legacy letters to give to them. In addition, I will present an exhibit entitled 'StoryCard,' where the pictures and stories will be exhibited and shared with many people in both our countries. I will also bring the Traveling Postcard project to Malawi."

This is where Lovell intends to involve local women. On November 15, from 1 to 5 p.m., she invites anyone interested to join her at 26 Camino Del Diablo, Orinda, to have their pictures taken. "All they need to bring is another woman or girl they would like to honor and be photographed with, and then tell their story. It's an opportunity to share one's voice with women across the world through art and creativity, making connections without ever leaving Lamorinda," she says.

It is a fund-raising event, and Lovell needs to raise \$5,000 for photographic and oral recording expenses for this venture. She asks for a minimum donation of \$35. If women are unable to come, but wish to donate and participate, she will send them a blank postcard with instructions. When in Malawi, she will embark on a similar project.

In addition to this event, there are concurrent essay contests, at JFK and in Malawi. The winner at JFK will travel to Malawi with all expenses paid while two winners will be selected from Malawi to receive scholarships toward a four-year college education in their African country. Plans also include the making of a video and a photographic documentary to preserve the stories of women, particularly those with HIV/AIDS.

Books are desperately needed, because many classrooms don't have any. There are only a handful in school libraries. JFK has collected more than 1,000 books to create a library at the Tulcombo Girl's School. Lovell explained her prime reason for participating in this project, saying "I have a deep connection to women. I want the women of Malawi to know other women care for them. I believe being engaged in a creative project that involves community and an exchange of cultures can be transformative to everyone involved."

For further information or to make a reservation to attend, contact Caroline Lovell at 925-969-33429, or email cslov@comcast.net You may also visit the website [carolinelovellphotography.com](http://carolinelovellphotography.com).



CAROLINE LOVELL

**Photographer Caroline Lovell** is creating postcards to share the stories of women in the United States and Africa. Proceeds will benefit African women who are HIV-positive.

**IT'S TIME**

TO CALL

**ALPINE**  
ROOF AND  
GUTTER  
CLEANING  
CO.

**254-5060**  
DIV. OF BLUE PINES  
TREE SERV.  
ORINDA, CALIF.

**FREE ESTIMATES**

**SIAM ORCHID**  
Esquisite Thai Cuisine

Authentic Cuisine  
of Thailand

- Family Owned
- 3 Generations of Thai cooking experience
- All sauces made fresh
- Full Bar

Lunch: Mon.-Fri. 11-2  
Dinner: Mon.-Sun. 4:30-9:00

23 F Orinda Way, Orinda  
(925) 253-1975

### Local Fundraising Event

November 15 1 - 5 p.m.  
26 Camino Del Diablo  
Orinda, CA

Bring another woman or girl to be photographed with your "Story-Card." Proceeds benefit women in Malawi, Africa, who are HIV-positive.

she found them distressed because they feared there would be no way for future generations, or those in the outside world, to know about the Malawian way of life. They also craved connections with women of other countries. She says, "To remedy this deep desire, I, with Caroline and seven other women from across the United States, and Masankho Banda, a Bay Area African educator from Malawi, will conduct a series of story-writing workshops. We hope to provide these women with the tools and training to write their own stories and with the ability to train others to do so."

Lovell continued. "My role is that of artist and photographer. I will be taking

### Orinda Community Center Auxiliary's 33<sup>rd</sup> Annual Holiday Bazaar



This is the Orinda Community Center's largest fundraising event. Over 60 vendors from near and far. 100% of the proceeds benefit the Orinda Community Center parks and programs.

Saturday, November 1st 10:00 - 4:30 pm

Sunday, November 2nd 11:00 - 4:30pm

Orinda Community Center 26 Orinda Way

~ Raffle Prizes and Silent Auction ~

~ Children's Art Drop Off ~

While you shop, drop-off your child, ages 3-8, in the art room  
\$5.00 per child, per hour. Saturday 11:00 - 3:00 and Sunday 12:00 - 3:00

~ Entertainment ~

Live Music for the adults and Roaming Clowns for the children

~ Featured Items: ~

Holiday Decorations • Children's Clothing • Food  
Handcrafted Apparel • Fine Jewelry • Accessories  
Bath and Skincare • Candles • Art  
Items for the Home • Handcrafted Note cards  
and much more!

OCCA is the sponsor of the annual Concerts-in-the-Park, Halloween Parade, Spring Egg Hunt and this Holiday Bazaar.  
For more information, please call the Orinda Community Center at 925-254-2445 or go to  
<http://old.ci.orinda.ca.us/parksandrec/auxiliary.html>



### Work with the Lamorinda Real Estate Home Team!

Knowledgeable,  
honest, and professional  
realtors with 22 years of  
experience making a  
winning combination.

just ask our clients

**Virginia Varni-Ratto**  
(925) 253-6215

[vvarni@pacunion.com](mailto:vvarni@pacunion.com)

**Paul Ratto**  
(925) 253-6227

[prat@pacunion.com](mailto:prat@pacunion.com)

[www.varni-ratto.com](http://www.varni-ratto.com)

**PACIFIC  
UNION**

BEST READS / BALANCED LIVING

# Best Reads: Recommendations from Book Industry

■ Ron Shoop discusses books on November 18

By MOYA STONE  
Staff Writer

The holidays are fast approaching and that means that Ron Shoop from Random House again will present his best-reading picks at the Orinda Library. The recommendation session will be at 7 p.m. on November 18. Part of the proceeds from book sales go to the adult literacy project, Project Second Chance.

Shoop presents regularly at Contra Costa County libraries, sharing what he thinks are the hot books of the season. His chosen titles are available for purchase, with a portion of the proceeds going to the literacy project and to Friends of the Orinda Library.

Project Second Chance offers free and confidential literacy instruction to adults 16 years and older. Since 1984, the program has improved reading, writing, and spelling skills of more than 4,000 adults. Shoop hooked up with Project Second Chance eight years ago when he was asked to give a talk on new books at the Pleasant Hill Main Library. Now he's a regular at all the local libraries, visiting Orinda twice a year. "This has been a great opportunity," says Shoop. "I get to talk about books I like, meet people, support Second Chance, all while doing my job."

Friends of the Orinda Library is a non-profit organization dedicated to supporting and improving library services in Orinda. The all-volunteer group provides the library

with materials and sponsors children's and adult events, runs the Friends of the Library Bookstore, and organizes book sales.

Coordinator of Project Second Chance, Susan Lynn, says they started these book events to help increase the program's support base. "We knew that people who love to read would care about people who can't read," says Lynn. The events have proved successful, resulting in a mailing list of more than 800 people, who donate time and money to Second Chance.

Shoop's presentations last around 30 minutes, during which time he tells a story about each book designed to "whet appetites." Ample opportunity is given for questions and audience discussion. Shoop provides handouts with basic information, such as title and author, as well as plot points and cover images of the books.

This event for the Orinda Library has grown in popularity, with an average attendance now standing at 30 to 75 people. Orinda Community Library Manager Caroline Gick says the library is excited to have Shoop back. "His knowledge and enthusiasm about all the new reads from Random House is not only inspiring and informative," says Gick, "it's also very useful - several of the books he talked about last year made it onto my gift list for the holidays."

The event is free and will take place in the periodical section of the Orinda Library. For more information about Project Second Chance, visit: <http://www.cclib.org/psc/psc.html>. For more information about Friends of the Orinda Library visit: <http://cclib.org/friends/ori.html>.

## BALANCED LIVING



Change is in the Air, Change is Everywhere!

Andrea Colombu

Are you noticing the change? These days it is almost impossible not to! Change has been the buzzword for quite a while now – and not just an empty word. We've been hearing about change from politicians, media talking-heads, financial experts and concerned environmentalists. We have seen change, formidable change, on Wall Street and Main Street, and we all have fully felt its ripple effect, in our homes, in our pockets, and I dare say in our psyche! So, how do we deal with change?

There are different kinds of responses and ways of dealing with change and not all of them are beneficial to our well-being. Some deny or resist change. Futile attempts to retain illusory control over the inevitability of change usually result in causing stress, worry, frustration and anxiety – all harmful states of being to both mind and body. Another response is to freeze. Although not as potentially harmful as resistance and denial, freezing in the face of change makes us feel stuck, powerless and incapable. Feeling stuck and unable to do anything, possibly for fear of doing something wrong, we create added internal stress and possibly, feelings of unworthiness. After all, one must always know what to do, otherwise something must be wrong with him or her!

The healthiest of all possible responses to change is to embrace it. By embracing the inevitable reality of change in our lives, we embrace life itself and, in the process, we relieve ourselves of so much unneeded and unnecessary stress. Life is fundamentally characterized by change! Whether we realize it or not, everything we experience is in a constant state of flux. Our bodies, our minds, our thoughts, our feelings, and our experiences are continuously changing. Nothing within us or outside us remains the same for long. Our body, for example, changes all of its cells within four to five years, literally recreating a new "model" of itself. Within days and weeks, we replace entire organs like the liver, our skin, our skeletal structure and stomach lining, to name a few. Our brain is now scientifically proven to change throughout the course of our life based on all of our experiences and life style. Our mind and our thoughts

are also constantly changing and adapting to our perception of our inner and outer worlds. The same is valid for our feelings and emotions – everything we experience is constantly dancing with the music of impermanence. If you don't believe it, try to follow your moods and thoughts throughout the day, or your self-impression, or your energy level, or your emotions. You will find that it is almost impossible to keep up with the multitude of changes you'll go through. Like a restless monkey, our mind jumps from one branch of reality to another, constantly seeking something to grasp in order to make us feel more secure and to provide us with a falsely reassuring sense of permanence.

Outside our body, things are no different. And yet, change is difficult to accept! We tend to like the comfort of familiarity and resist the newness of the different. It is somewhat natural to be suspicious and intimidated by the unknown, but when you think about it, most of our life is unknown. Our habitual patterns of adaptation to the familiar are deeply rooted in our psyche and keep us attached to what we know, even if what we know is not what we really want for our happiness and well-being.

The truth is that our lives, and everything we experience, are impermanent. Remember the old saying, "nothing is written in stone." Well, this could not be truer than in our lives! Becoming mindful of the fluctuation of our experiences, thoughts, bodily states and the reality of change helps us to lead a more balanced and fulfilling life. By attuning to the reality of impermanence, we stop wasting precious energy and time, we stop fighting the inevitable and become free to create or recreate our experiences and our lives. By embracing the intrinsic impermanent nature of life, we connect to the nature of what it is to be alive and begin moving with more ease at life's rhythms and to experience the fullness of our being-ness.

Until next time, be well, embrace life, enjoy your holidays and many blessings!



**Chinese Fine Dining and Take Out**

voted  
Best Chinese Restaurant in  
Contra Costa County  
by S.F. Chronicle

1 Orinda Way - 253-9852

M-Th 11:30 a.m. - 9:30 p.m.  
Fri. - Sat. 11:30 a.m. - 10 p.m.  
Sun. 12 p.m. - 9:30 p.m.  
Closed Tuesday



**IRONWOOD**  
ENGINEERING COMPANY

Civil & Structural Engineering  
Earthquake Strengthening  
Foundation Repairs  
Retaining Walls  
Drainage  
Remodels  
Additions  
New Construction  
Licensed Engineers  
Leak Investigations  
Expert Witness  
Property Purchase Inspections

510 / 524-8058



925 254-8585

View All Area Listings Online...

**CLARK THOMPSON**  
REAL ESTATE BROKER

[www.clarkthompson.com](http://www.clarkthompson.com)



SERVING LAMORINDA SINCE 1979

Specializing In:  
Spot and Stain Removal  
Orientals and Handmade Rugs  
Upholstery cleaning  
Water damage  
Odor removal

We Clean for Health as well as Appearance

We Clean with **Green T.L.C.**

254-2866

John Kirby  
Owner





HOME SEET HOME

# HOME SWEET HOME

## Rainy Season: French Drains



Janice Gatlin

As we enter into our rainy season, thoughts drift to last year and water under houses. In this article, we'll look at causes of water under homes and the use of French drains to remediate.

Water can get under your house from several sources: a plumbing leak (house or irrigation), sprinklers that are over watering or pointed incorrectly, high water table, run-off from a neighbor's land or rain water. When water is coming from the outside in (ie: not a house plumbing leak or high water table), the key is to remove the water before it reaches the foundation of your house.

The easiest way to accomplish this is through "French" drains. Essentially a French drain is a trench that is dug at some distance from your house, usually in a parallel line to the house and perpendicular to the direction of flow of water, and then backfilled with rock. As the water approaches your home, it meets the drain, is trapped and so doesn't reach your home. The depth, length and number of these drains (trenches) depend on where

the water is coming from, how deep it is, and where you want it to go.

When I moved into my upslope home, there were no homes on either side, and I had no drainage problems. But years later, when the neighbors on one side built their home, I suddenly had water under my house during the rainy season. It was clear that the water running down the hill behind my house, which previously drained onto their lot, was now redirected by the existence of their home to underneath my house.

Doing some testing and investigation, I found the best system for my home was a series of French drains. I installed three parallel drains the width of my home, parallel to the back of my home (which was perpendicular to the direction of the water flowing off the hill behind my house). The first drain was about 10 feet behind my house, the next five feet behind that and the third another eight feet behind that. The drains were all three feet deep, which I had determined was the maximum depth

the water went under the soil.

I then added two more drains the length of my house on either side, parallel to the foundation, and connected these to the drains in the back. So I ended up with a sort of u-shaped arrangement that allowed all the collected water to drain on down the hill after it collected in the French drains. I then connected these to underground drain pipes that drained well away from my house.

I also added several clean-out areas consisting of four plastic boxes (two square and two rectangular) with plastic grates on top inserted in different parts of the trenches. In these clean out areas, any soil or other debris that might clog the system could be cleaned out to keep it running smoothly.

Check under your home mid summer and during the middle of the rainy season to see

if there is any water under your home. If you find water, consult with a licensed landscaping contractor or if it is very serious, you can also call a drainage or engineering contractor for advice.

While French drains are excellent for slowing or stopping the flow of water from outside sources, you may also have other factors such as a high water table in which case French drains won't completely resolve your problem. However, consultation with the appropriate professional will help you determine which remedies will work for you.

Janice Gatlin is a local General Contractor and owner of Always the Best Home Repairs & Construction. She can be reached at 925-254-9545 or [www.AT-Bremodel.com](http://www.AT-Bremodel.com).

## Long Distance Grandparenting – Tips and Tales by Those Who've Been There

By DOROTHY BOWEN  
Contributing Writer

“Over the river and through the woods” used to be the way to grandmother's house, but today that little trek could span states or even continents. But still, grandparents want to keep in touch with their offspring.

A new book, *Long Distance Grandparenting: Connecting With Your Grandchildren From Afar* by Willma Willis Gore, addresses these concerns with practical suggestions as well as warnings about pitfalls along the way. Gore will sign copies of the paperback at Orinda Books on Thursday, November 13, 1 to 4 p.m. A book signing for her previous work, *Just Pencil Me In: A Guide to Moving After 60*, drew record crowds and sales.

Gore has been a grandmother herself for 25 years as well as a frequent mover. To research the latest book, she interviewed 60 other grandparents. The book covers topics including: when and how to visit ground rules, risks and rewards of giving advice, going postal, cyberspace to the rescue, grandparents remembering their own grandparents, and intergenerational vacations. It doesn't avoid difficult topics like broken families and includes a bibli-

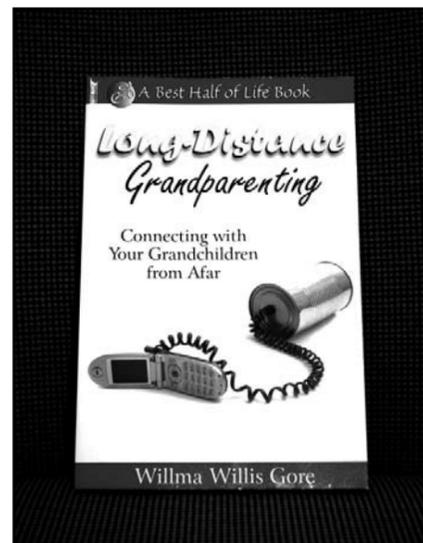

SALLY HOGARTY

Willma Willis Gore will sign her new book at Orinda Books on November 13 from 1-4 p.m.

ography for more information.

Gore lives in Sedona, Arizona, where she continues writing and leading writing workshops. Her column, "Sedona's Sassy Senior," ran for two years in the local paper, *The Villager*. Recently, she won first prize in the short story category by the Society of Southwestern Authors.



**EFO - Educational Foundation of Orinda -**

wishes to thank these donors for their generous in-kind contributions in support of Orinda schools:

**American President Lines**  
**Barbara Llewellyn Catering Beverages & More**  
**Jill Gelster, The Orinda News**  
**Concord Graphic Arts**  
**Diane Goldsmith, Square Moon**  
**Martin Johnson and Jenny Wodinsky**  
**McDonnell Nursery**  
**Mechanics Bank**  
**Petra Michel**  
**Prudential California Realty**  
**Village Associates Real Estate**

For more information or to donate online, please visit [www.orindaefo.org](http://www.orindaefo.org)

SUSHI

Your best catch is Orinda's

NIWA RESTAURANT

S.F. Chronicle 1/4/2002



NIWA RESTAURANT

Sushi Bar

Japanese Cuisine & Chinese Cuisine

Mon.-Thur.:	11:00 a.m. - 2:30 p.m.	4:30 p.m. - 9:30 p.m.
Fri.:	11:00 a.m. - 2:30 p.m.	4:30 p.m. - 10:00 p.m.
Sat:	11:45 a.m. - 10:00 p.m.	
Sun:	Closed	

(925) 254-1606

1 Camino Sobrante #6  
(across from Safeway)

“Always...The Best”

Home Repairs & Remodeling

Serving Orinda for 28 Years  
References Proudly Given • Competitive Rates  
Complete Handyman Services!

925-254-9545

Lic#760085    Bonded & Insured

<ul style="list-style-type: none"> <li>• Electrical</li> <li>• Plumbing</li> <li>• Carpentry</li> <li>• Siding</li> </ul>	<ul style="list-style-type: none"> <li>• Tile</li> <li>• Floors</li> <li>• Dry Wall</li> <li>• Kitchen and Bath Remodeling</li> </ul>
---	---



- Windows
- Doors
- Decks



Baan Thai RESTAURANT

Eat Healthy, Live Healthy

ORGANIC SALADS MADE FRESH DAILY.  
MANY VEGETARIAN OPTIONS.  
WE COOK FROM FAMILY RECIPES.

FOOD TO GO, CATERING & GIFT CERTIFICATES ARE AVAILABLE

Open for Lunch:

Mon. - Sun. 11:30 a.m. to 3:00 p.m.

Dinner: Sun. - Thurs. 4:30 - 9:30 p.m.

Fri.-Sat.: 4:30 - 10:00 p.m.

99 Orinda Way, Orinda

(925) 253-0989



For Outstanding Real Estate Results

Residences

Investment Properties

Retirement Retreats

Industry Advice

Since 1987

David Pierce

BROKER-REALTOR

has been helping clients realize their goals and achieve their objectives.

For your complimentary consultation, call David today.





925-254-5984

510-325-7653

[david.pierce@prurealty.com](mailto:david.pierce@prurealty.com)

[www.davidpierce.net](http://www.davidpierce.net)

Top 1% Nationwide



## CALENDAR

## ON THE CALENDAR

## NOVEMBER

- 1 **Orinda Community Center Auxiliary Holiday Bazaar**, 10 a.m. to 3 p.m., Orinda Community Center. Continues November 2. 925-377-5173.
- 12 **Second Wednesday Book Group**, 3 p.m., Orinda Books. Reading and discussion of *No Ordinary Time* by Doris Kearns Goodwin. 254-7606.  
**Orinda Intermediate School's** production of *Sherlock Holmes and the Hound of the Clackervilles*. See article this page.
- 13 **Orinda Books Author Appearance**, 4 p.m. Garth Stein will discuss and sign copies of *The Art of Racing in the Rain*. 254-7606.
- 18 **World Affairs Book Group**, 4 p.m., Orinda Books. Discussion of *Hugo: The Hugo Chavez Story from Mud Hut to Perpetual Revolution* by Bart Jones. Call 925-935-1565.  
**Orinda Owls**, 7 p.m., Orinda Books. Discussion of *The Bonesetter's Daughter* by Amy Tan. 254-7606.  
**Holiday Book Recommendations**, 7 p.m., Orinda Library. Ron Shoop of Random House will speak. 254-2184.
- 19 **Miramonte Fall Play**, 7:30 p.m., Miramonte High School. *The Complete Works of Shakespeare, Abridged*. Continues November 20, and 21. 925-376-4423.
- 21 **Montelindo Garden Club**, 9 a.m., Orinda Community Church, 10 Irwin Way. Garth Jacober of Mt. Diablo Nursery on perennials and pruning. Free. 925-415-2397.
- 22 **2nd Annual Tim Truesdell MS Walkathon**, organized by Miramonte students, 10 a.m. - 3 p.m. at Moraga Commons.

## AT THE LIBRARY

All events are free unless otherwise specified.

## Adult Programs

- 1 **Fireside Chat**, 7-8 p.m., *Joe Turner's Come and Gone*, with Berkeley Repertory Theatre's trained docents discuss the production.
- 12 **Lamorinda Reads! Grand Finale**, 7-9 p.m., Library Auditorium. *Funny in Farsi* author Firoozeh Dumas will speak.

## Children's Programs

- 5 **Paws to Read**, 3:30 p.m. Children in grades 1-5 practice reading with a furry listener in 25-minute sessions. Repeats at 4:30 p.m., and continues November 12, 19, and 26. Sponsored by the Friends of the Orinda Library.
- 18 **Peek-a-Boo**, 10:15 a.m. Story time for newborns to 1-year-olds and their caregivers. Repeats at 10:45, and continues on November 25.  
**Toddler Lapsit**, 10 a.m. Stories, songs and bounces for 1- to 3-year-olds and their caregivers. Repeats at 10:30 a.m. Also November 19, 25, and 26. Please choose one story time per week.
- 22 **Saturday Morning Live!** 11 a.m. Family story time for 3- to 5 year-olds. Meets in the Picture Book area. Also November 29.

For more information on library programs, call 254-2184.

## MEETINGS:

## CITY/FIRE/SCHOOL DISTRICT MEETING SCHEDULE

- Acalanes Union High School District**, first and third Wednesdays, district office, 1212 Pleasant Hill Road, Lafayette, 7:30 p.m.
- Friends of the Orinda Creeks**, Orinda Library, May Room, fourth Wednesday, 8 a.m., 253-1997.
- City Council**, first and third Tuesdays, 7 p.m., Library Auditorium, www.cityoforinda.org.
- Historic Landmarks Committee**, fourth Tuesday, 3 to 5 p.m., Library Garden Room, public is welcome, for information, call 925-788-7323.
- Friends of the Orinda Creeks**, fourth Wednesday, 8 a.m., May Room, Orinda Library. Call 253-1997.
- Moraga-Orinda Fire District**, third Wednesday, 7 p.m., Administration Building, 1280 Moraga Way, Moraga.
- Orinda Union School District Board of Trustees**, OUSD Conference Room, 8 Altarinda Road, 4 p.m.
- Planning Commission**, second and fourth Tuesdays, 7 p.m., Library Auditorium, 253-4210.
- Parks and Recreation Commission** Second Wednesday, 7 p.m., Community Center, room 7, 254-2445.
- Lamorinda Sunrise Rotary**, Postino's in Lafayette, 7 a.m. every Friday, 254-0440, ext.463.
- Orinda Rotary**, Community Center, every Wednesday at noon, 254-2222.
- Orinda Association**, Orinda Library, May Room, second Monday, 7:30 p.m., 254-0800.
- Orinda Historical Society**, third Wednesday of the month, OHS Museum, 3 to 5 p.m., 254-1353.
- Orinda Job's Daughters**, first and third Monday, 7 p.m., 9 Altarinda Road, 925-283-7176.

CALENDAR BY CHRIS LAVIN

Send calendar items to [chrislavin@earthlink.net](mailto:chrislavin@earthlink.net)

## Miramonte Chooses Wacky Shakespearean Spoof to Liven Up the Fall

By SALLY HOGARTY  
Editor

Hold on to your hats and prepare for a roller coaster ride through Shakespeare's canon of plays as the drama students at Miramonte High School present *The Complete Works of William Shakespeare (Abridged)* November 19 - 21.

Written by Adam Long, Daniel Singer, and Jess Winfield of the original Reduced Shakespeare Company, the show doesn't require any previous knowledge of Shakespeare's works. The fast-paced, irreverent romp through the Bard's 37 plays in 97 minutes promises lots of laughs whether you are familiar with the plays or not. The show has been a hit everywhere including London, where it is one of the longest running comedies on record.

"I chose the play because it's zany, silly, wacky, fun, clever and quick, which perfectly describes my advanced drama students this year," says drama teacher Heather Cousins. "Although the play is originally written for three actors, many



SALLY HOGARTY  
Colin Cramer and Helen Mead practice a fight scene in Miramonte's production of *The Complete Works of Shakespeare Abridged*.

high schools effectively adapt it for a larger cast due to its flexible casting."

Judging from a recent rehearsal, the actors seem to be having as much fun preparing the production as audiences will have seeing it.

Shows take place November 19, 20 and 21 at 7:30 p.m. Call 925-376-4423 for more information.

## The "Curse" Comes to Orinda Intermediate School



PETRA MICHEL  
OIS students rehearse the mystery *Sherlock Holmes and the Hound of the Clackervilles*, which plays November 12-15.

By D.D. FELTON  
Contributing Writer

If you need something more light-hearted than reading current newspaper headlines, try the Bulldog Theater at Orinda Intermediate School. Clive Worsley directs 60 students in *Sherlock Holmes and the Hound of the Clackervilles* November 12-15.

In this funny spoof, Charlie Clackerville suddenly hears a hound howling. It creeps closer and closer until it literally frightens poor Charlie to death. Sherlock Holmes and Dr. Abigail Watson pose as exterminators to solve the case.

In the tradition of The Bulldog Theatre Company, two different casts will perform a total of six shows at the OIS Multi Purpose Room, 80 Ivy Drive. Additionally, 24 students on tech crew bring order, lights, sound and scenery to the stage. Produced by Kathy Simon, the show has many parent volunteers including events and production managers Petra Michel and Aubyn Severson.

Showtimes are November 12 and 13 at 5 p.m.; November 14 at 5 and 8 p.m.; and November 15 at 3 and 7 p.m. Tickets are available at [www.orindaschools.org/OIS](http://www.orindaschools.org/OIS).

## New Salsa Dance Classes Begin in November



CONTRIBUTED PHOTO  
Instructor Tomaj Trenda (L) and the Orinda Community Center will host a series of new salsa dance classes on Monday nights, November 3 - December 22 (Beginning class at 7 p.m.; Intermediate class at 8 p.m.). These classes are open to everyone and no partner is required. Call 254-2445 to register. Trenda is also hosting a salsa dance party on Saturday, November 8, from 8 - 11 p.m. at the Orinda Masonic Hall. The evening includes two dance lessons, free drinks and food, fun prizes and give-aways. Call Trenda at 415-505-3536 or go online to [www.SalsawithTomaj.com](http://www.SalsawithTomaj.com).

## got muscle?

Maybe it's time to treat your body to some special attention.



Call Carol at  
**Full Life Fitness**  
to discuss your fitness goals.  
Private studio

253-7753

Personal Fitness Trainer

Certified by the  
American Council on Exercise and the  
National Academy of Sports Medicine

AROUND THE TOWN

Long Time Residents Celebrate 60 Years of Marriage



CONTRIBUTED PHOTOS

**Cameron and Lorraine Lyon** (shown above at their wedding on Long Island 60 years ago and today) celebrated their diamond wedding anniversary in October. The happy couple moved to Orinda in January, 1960. They were sent congratulations from the White House. For other couples interested in receiving such a greeting for 50th anniversaries on up, go to [www.app1.whitehouse.gov/greetings](http://www.app1.whitehouse.gov/greetings).

a living lean meal in minutes



Prepare your Living Lean meal in minutes with delicious and nutritious choices from Diablo Foods. With selections such as pre-marinated chicken fajitas from the butcher shop, oven roasted turkey from the deli to fresh fruits and vegetables from produce, Diablo Foods is well stocked with healthy choices to fit your Living Lean lifestyle.

For information about the Living Lean Personal Training and Food Program contact Sheena at 925-360-7051.

Diablo Foods 3615 Mt Diablo Blvd. Lafayette, CA 94549 (925) 283-0737

live better live lean

body makeovers by Living Lean



chris del monica

**"Living Lean helped me to overcome my fear of another failed effort to lose weight".**

I have been on and off every type of diet there is and have struggled with weight loss my whole life until I found the Living Lean Program. In 12 weeks I lost 15 lbs and my body fat percentage went from 29% to 20%. My blood pressure went from 138/80 to 110/78. The program motivated me to adapt healthy habits into my lifestyle, and to overcome my fear of another failed effort to lose weight. I realized that having a program that makes sense scientifically and that I could be motivated to stick to consistently was the combination I had been missing all my life. Because of Sheena and all her wonderful trainers, I look better, feel better, and have a "yes I can attitude". Thank you Sheena!

—Chris Del Monica



**The Living Lean Program Studios in Orinda and Now in Montclair Village.** Call Sheena for reservations at **(925) 360-7051** Space is limited so call today.

Iranian Art in Library Gallery Compliments Lamorinda Reads

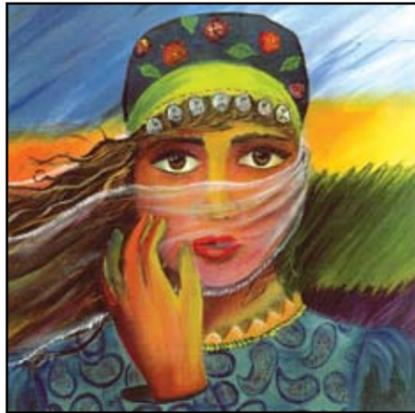

CONTRIBUTED PHOTOS

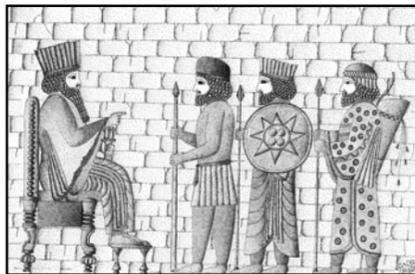

The above photos of Iranian children's art will be part of the November exhibit at the Orinda Library Gallery. The children's art is part of the "Wonders of Persia Art" exhibition organized by Orinda resident Nazli Irani Monahan. Iranian children ranging in age from 7 to 18 submitted art depicting the beauties of their country. The exhibition also includes Iranian art from the Hourian Fine Art Gallery in San Francisco. Iranian born artist Mohammed Hourian will display his own works plus other Iranian artists in watercolors, oils, and acrylics. The exhibit runs through the month of November.

The art work exhibit compliments the second annual community reading program, Lamorinda Reads, which began October 13. The book chosen for this year's three community read is Firoozeh Dumas' *Funny in Farsi: A Memoir of Growing up Iranian in America*. An author's and artist's reception will be held November 12 at 7 p.m. in the Orinda Library Auditorium. The evening begins with Dumas speaking followed by the reception featuring hors d'oeuvres from Bijan Restaurant in Walnut Creek. For more information on Lamorinda Reads or the gallery exhibit, call 254-2184.

Move of the Month Oblique V-UP



a. Lie on your side with your body in a straight line. Put your hands behind your head.



b. Keeping your legs together, lift them off the floor as you raise your top elbow toward your hip. The range of motion is short, but you should feel an intense contraction in your obliques.

—COURTESY OF LIVING LEAN 925-360-7051.



CoreKinetics

PILATES

EXERCISE AND REHAB WITH

COREKINETICS

IN ORINDA

- PRIVATE AND SEMI PRIVATE SESSIONS
  - EQUIPMENT AND MAT WORK
  - RESISTANCE, NON-WEIGHT BEARING
  - PROMOTES WELL-BALANCED, EFFICIENT MOVEMENT IN YOUR DAILY LIFE!
- 925-708-3279  
50 Vashell Way #120

PLEASE CALL FOR AN APPOINTMENT



BUSINESS BUZZ

◆ BUZZ from page 24

was 43,” says retired stockbroker Ralph Witherell. “It is very challenging and difficult in the beginning. I made a commitment and went consistently and started getting positive results. After seven years of practicing four times a week, I am in the best shape ever. It exercises every muscle and joint in the entire body.” Witherell’s family claims he is more pleasant when he does yoga. “Nicole and all the teachers are great,” he adds.

Students range from 12- to 70-years-of-age. “This practice requires a lot of attention and focus, so 12 is probably the youngest student we have. It appeals to people of all ages and any background. People find it is a place to de-stress and clear the mind,” says Lyell.

The Bikram Yoga studio at One Orinda Way, Suite 4 is busy now with more and more people dropping in for a session. They have a special offer which includes two weeks of unlimited sessions for \$29. Show-



SALLY HOGARTY

Author Terri Moss with her therapy dog Cody.

everyday stories that illustrate a larger scene of the importance of the contribution healthcare professionals make. I edited the emails for book format, designed and printed a quality book. In turbulent financial times, it is nice to get a meaningful gift that supports a person in his or her chosen career,” explains Moss. *Healing With Heart: Inspirations for Healthcare Professionals*, is available for purchase on Moss’ website, [www.mosscommunications.net](http://www.mosscommunications.net). It has been well received at various hospitals within the Kaiser Permanente, Sutter Health, John Muir, Catholic Healthcare West health systems, as well as with Contra Costa Health Services.

Moss has a background in marketing and employee communications, with over 20 years experience working in human resources for large Fortune 500 companies. She established Moss Communications in 1994 and enjoys owning her own business. “We moved to Orinda in 2001 for the usual reasons – the excellent public school system and the superb library,” smiles Moss. Her husband, Jack Bookbinder, is in market research at Kaiser Permanente. The couple’s son, Daniel, attends 3rd grade at Del Rey School. Moss enjoys sharing her therapy dog, Cody, with the elderly at the Lamorinda Adult Respite Center, which operates at the Holy Shepherd Lutheran Church in Orinda. Cody is multi-talented and participates in the Paws To Read program at the Orinda Library. “Lin Look brought Paws To Read, an innovative and wonderful program, to the Orinda Library, and I am very grateful to her for doing that,” says Moss.

Definitely check this out if someone you know and care about works in the healthcare industry. For more information about Moss Communications or to order copies of *Healing With Heart: Inspirations for Healthcare Professionals*, visit the website at [www.mosscommunications.net](http://www.mosscommunications.net) or give Terri Moss a call at 377-5288.



SALLY HOGARTY

Owners Amy Lyell (front) and Nicole Payne (back) demonstrate yoga poses with instructor Lee Michalson at their Orinda studio.

ers are available so students may bathe and head off to work after their session. For more information, please call Amy Lyell at 858-2973.

**Moss Communications**

Orindan Terri Moss recently co-authored and self-published, *Healing With Heart: Inspirations for Healthcare Professionals*, an inspiring book suitable for gift giving this holiday season. This collaborative and uplifting book came about in an interesting way. Moss read a series of weekly emails Martin Helldorfer, senior vice president of Mission, sent over a period of six years to employees at Exempla Healthcare and decided the messages needed to be shared with a larger audience. Helldorfer is a former De La Salle monk, a psychologist and serves as a senior executive of a healthcare system in Denver, Colorado. “Healing With Heart supports a work climate that puts people first. Compassion, authentic communications, effective teamwork, and stellar leadership stem from the fundamentals found in *Healing With Heart*, our common humanity, our shared goals and our drive to excel,” explains Moss.

I became very inspired and my project was about helping people to be more authentic in their work. Martin wrote about

**ORINDA NEEDS A CHANGE OF LEADERSHIP**

*On November 4th You Have An Alternative*

**Send a message to the Orinda City Council!**

On election day you can vote for two candidates for City Council. Be different and vote for just one candidate. Don’t vote for either incumbent and send a message to the entire Council.

**DON’T VOTE FOR EITHER INCUMBENT**



**THE ALTERNATIVE**  
**DR. BOB LARSEN**  
**ORINDA CITY COUNCIL**

**Vote For Dr. Bob Larsen - The Alternative**

Paid for by Dr. Bob - The Alternative



**“Your Comfort Is Our Number One Priority”**



**The Haddon Family, Orinda Residents, Owners / Operators**

Do business with a neighbor. Haddon Heating and Cooling specializes in residential furnaces, heaters, air conditioners, ductwork, repairs, upgrades, maintenance and services.

**(925) 521-1380 • [www.haddonheatingcooling.com](http://www.haddonheatingcooling.com)**

5702 Marsh Drive, Suite T, Pacheco, CA 94553

Fax: 925-521-1381 • License # 855456

Monday - Friday 7 am - 5 pm (closed for lunch)



**FREE ESTIMATES • FAST SERVICE**

**Integrity ♥ Expertise**

**35 year Orinda Resident**  
**(925) 253-4611**



**Laura Abrams, M.B.A.**  
**Residential Sales Associate**

**Orinda Office, Coldwell Banker Real Estate**  
[www.lauraabrams.com](http://www.lauraabrams.com)   [laura@lauraabrams.com](mailto:laura@lauraabrams.com)



BUSINESS BUZZ

# Business Buzz

## Putting a Personal Face on the Face of Business

Valerie Hotz



To send items for consideration, email Hotz at v.hotz@att.net.

**A.J. Nails**

A person can live in Orinda for 20 years

and not consciously have taken notice of the handful of assorted businesses located at One Orinda Way. Hsiang's Chinese restaurant is in suite number 1 and clearly visible from the street. Lamorinda Martial Arts is

immediately to the left, and wrapped clear around the corner - past the vibrant purple verbena and lavender - in suite number 3 is A.J. Nails, which is actually visible to motorists traveling on Camino Pablo. A big plus of this location is excellent parking for patrons.

Take the time to see what these businesses have to offer, and you won't be disappointed. Kim Nguyen of A.J. Nails has 20 years of experience as a manicurist. Nguyen is Vietnamese, and she left her homeland by boat in 1975 at the age of 17. "Things happened so fast and quickly. I left without my family, and it was very hard." Think about that experience for just one minute.

In addition to having a nail salon in Lafayette, Nguyen owned the US Mail business there for several years. When her younger sister, Ngoc, asked her to step in at her Orinda nail salon last February, Nguyen responded promptly. "My sister is pregnant, and she asked me to help out during this

often encounter in nail salons. Waxing is available. Rates are very reasonable. A manicure is \$12, pedicure \$22 and a French manicure runs \$15. A full set of nails is \$29. Gift certificates are available and a great idea with the holidays that are right around the corner.

"This is the best little nail shop in Orinda. I went to Kim when she was in Lafayette and followed her here to Orinda. A.J.'s is very kid friendly. My 5-year-old son loves coming here," says Monica Clarke of Moraga as she is having her French manicure done by Nguyen.

A.J. Nails is open Monday 10 a.m. - 3 p.m., Tuesday through Friday 10 a.m. - 7 p.m., Saturday 9 a.m. - 6 p.m. and Sunday 11 a.m. - 5 p.m. Please call ahead for an appointment at 258-9007.

**Bikram Yoga**

Continue on past A.J. Nails, and you will see the Bikram Yoga sign at suite number 4. This studio opened at this location about five years ago and since December of 2007, it has been owned and managed by Nicole Payne and Amy Lyell. If you have never experienced Bikram Yoga, you are in for a rigorous, yet satisfying and beneficial experience. A floor-to-ceiling mirror stretches from one end of the studio to the other, enabling the practitioner to observe himself throughout the session, with a gleaming hardwood floor and butterscotch walls rounding out the look of the studio.

This particular yoga practice requires the studio maintain a temperature of 105 degrees (think Fresno or Bakersfield with no air conditioning in late July). "The heat is very important for flexibility, and when a person heats up internally it allows them to go into the posture. Our sessions are 90 minutes long. We include two breathing exercises and 26 postures," explains Lyell. There are sessions as early as 6 a.m. and as late as 6:30 p.m., so you are likely to find something that will work with your schedule. All classes are for beginners. "We do the same routine and provide good feedback so you can gauge your progress from class to class," says Payne, who has been teaching Bikram Yoga for seven years.

This particular yoga practice was developed by Bikram Choudhury in Calcutta, India, where he lived on an ashram and in fact had a guru. "People came to him with common medical conditions such as diabetes, arthritis, heart disease and spinal issues. He provided them with a diet and a yoga posture to keep during the day. Choudhury created postures to maintain health and every posture has a direct medical benefit associated with it, and this evolved into what we know as Bikram Yoga," explains Lyell. Today, there are 300 practicing studios worldwide.

"I had been sitting at a desk for 20 years and decided to try Bikram yoga when I [SEE BUZZ page 23]

*First class luxury all the way at the Gina Khan Salon*

*Gina Khan- Winner, Haircolor USA Colorist of the Year & Creative Artist*

With complimentary iced cappuccinos and lattes and fabulous massaging shampoo chairs, you'll feel the luxury of being in the hands of our Experts. New Guests- mention this ad for a complimentary treatment and blow-dry.

**GINA KHAN SALON**

925-287-8008

173 MAIDEN LANE, SAN FRANCISCO  
1255 S. MAIN STREET, WALNUT CREEK  
WWW.GINAKHAN.COM  
(ABOVE ANN TAYLOR LOFT)



Kim Nguyen of A.J. Nails.

time. She has been at this location for three years, and I am very pleased to be of help to our customers," says Nguyen.

The rainbow array of nail polish colors beats any I have seen anywhere locally, hands down. A bank of comfy massage chairs, complete with footbaths, stands waiting for customers who are treating themselves to a fine pedicure. Absent is the suffocating smell of varnish that you

## Is Your Broker Making You Broke? Call Us

- Providing over 26 years of sound, trustworthy financial advice to over 300 clients.
- A 100% Fee Only, Independent Advisory Firm with over \$250 million under management.\*
- Experienced, dedicated, caring professionals - CFP, MBA, CMFC on staff.

\*AUM 9/10/08

Call now to schedule your **Free Initial Meeting!**  
Phone: 925 - 299 - 1500     \$500,000 Portfolio Minimum

**Capital Advantage**  
RETIREMENT PLANNING & INVESTMENT MANAGEMENT

3708 Mt. Diablo Blvd, Suite 200 • Lafayette, California 94549 • www.CapitalAdvantage.com

Jumpstart Your Weight Loss

Jumpstart Medicine offers a medically-supervised weight loss program individually designed for men and women looking to lose weight safely and effectively. On average, our patients lose 2 to 3 pounds per week over the course of 12 weeks. Most patients feel great, have no hunger, and stay highly motivated due to quick results which they can see and feel.

How much do you want to lose?

**jumpstart**  
MEDICINE

Walnut Creek • San Ramon  
925-277-1123 • www.jumpstartmedicine.com

## LETTERS TO THE EDITOR

## ◆ LETTERS 2 from page 20

**Proven Commitment**

As an Orinda City Councilmember, Victoria Smith has provided leadership and support to Orindans for the past four years. In 2004, my husband Sarge and I recognized her commitment to the betterment of our community in a caring, fiscally responsible manner. I don't need to repeat her accomplishments during these last years - you can read about them elsewhere. What I must stress is that we need the benefit of her ongoing efforts today, and so I most heartily encourage you to vote to return Victoria to the Orinda City Council in 2008 to continue those efforts.

— Sue Littlehale

**Concerns about Measure E**

I have been given the opportunity to endorse Measure E, a \$93 million bond measure. I have some serious concerns. Proponents are encouraging a Yes vote based upon the premise that the bond measure "does not raise tax rates."

Tax rates may not go up, but this is a new tax. Seniors exempt from the existing bond will not be exempt from Measure E.

This is the type of spending that has gotten individuals, corporations and our nation into serious trouble. As a fiscally prudent Democrat, I am sure my Depression era Republican parents would want me to speak out. Many voting for this bond won't be alive when it is paid off. Twenty-five million dollars for adult education is a significant portion of the bond. For these reasons I have serious concern about the wisdom of this measure.

The Orinda City Council unanimously voted support for Measure E. There was no discussion about its cost nor adverse effects that its passage will have upon an infrastructure bond measure for our city. The Orinda Unified School District is considering a parcel tax. How many property tax assessments can we afford at a time when Orindans are retired, unemployed, underemployed or cutting back expenditures? Not everybody in Orinda makes over \$100,000. The city council has again abdicated its responsibility for safeguarding the community's financial well-being. At risk of becoming a pariah in a town where I have always supported the schools, I am disappointed with the council's fiscal irresponsibility and questionable judgment.

— Robert C. Larsen

**History of Service**

Smart. Dedicated. Honest. Hardworking. Open-minded. Those are the qualities I want in our town leaders and those are exactly the qualities possessed by Victoria Smith.

A long time resident and serial volunteer, Victoria Smith steps up when the community needs help. Her resume of service to the community is long and varied and includes stints as a planning commissioner, a scout leader, parent club board member and mayor. What I like most about Victoria is not that she is working hard to improve our downtown (she is), or that she has fought for improve garbage collection services (she has), but that she does all that she does because she loves Orinda and values community service.

Victoria Smith is exactly the kind of person we need on the city council and I hope you will vote to elect Victoria Smith to the Orinda City Council on November 4.

— Alex Evans

**Infrastructure Solutions**

The Orinda City Council formed a Revenue Enhancement Committee to study new ways to tax citizens to fix Orinda infrastructure. New taxes for infrastructure are not necessary since existing taxes could

fix our infrastructure?

Infrastructure Solution: Orinda detaches from Moraga/Orinda Fire District and forms an Orinda Fire District. Orinda forms an Orinda Police Department instead of contracting police services from the county.

Why do we need to detach from Moraga/Orinda Fire District (MOFD) and form our own Orinda Fire District? If we stopped subsidizing Moraga, existing tax money would be available for Orinda infrastructure.

The 2008-09 average per capita property tax for fire districts shows Orinda pays \$615, Moraga \$316, Lafayette \$312, Danville \$368, and Walnut Creek \$259. In 2008-09, Orinda's tax contribution to MOFD is 65 percent while Moraga's tax contribution is only 35 percent.

If Orinda had our own Orinda Fire District in 2008-09, we would have saved more than \$1.6 million annually. This \$1.6 million savings would increase annually to approximately \$3.6 million in 2013-14 including new development taxes. This \$3.6 million savings is over and above the cost to run Orinda's three fire stations.

Why should Orinda form an Orinda Police Department? Moraga spends \$1 million less for their own Police Department than Orinda spends contracting services from the county.

Having our own Orinda Fire District and Police Department would provide approximately \$5.6 million of taxes in 2013-14, which could be used on infrastructure — \$3.6 million could be saved with our own Orinda Fire District; \$1 million could be saved with our own Orinda Police Department; \$1 million that Orinda budgets annually for roads; giving us \$5.6 million existing taxes available for infrastructure in 2014.

The Orinda City Council candidates should take a pledge to oppose any new taxes for infrastructure because \$5.6 million in existing taxes by 2013-14 is more than Orinda can spend annually. No new taxes are needed.

— Vince Maiorana

**Elect Bob Larsen**

We enthusiastically support Dr. Bob Larsen for city council for many reasons, not the least of which is the fact that we have known him for 12 years, both personally and professionally. His intelligence and integrity is above reproach. He is able to solve problems quickly and efficiently while working with people of extremely diverse backgrounds and interests. He is an experienced business owner and an accomplished medical doctor, honored with many professional achievements. Last but certainly not least, his ideas for improving our community are long overdue. All Orinda residents should be so fortunate to have someone like Dr. Larsen take an active interest in bettering their community.

Not only does Dr. Larsen support continued public school excellence and stepping up the repaving of our horrific public roads, but he sees a critical opportunity to improve our Orinda community tax base and retail experience. Have you ever asked yourself why there are so many retail vacancies and such high business turnover here? Why do businesses choose other small towns nearby to locate to? Ask any store owner. They will tell you that Orinda is nearly impossible to deal with. We all end up paying a very high price since we have to personally fund more of our improvements or not fund them at all.

Dr. Larsen advocates a healthy business environment not just for tax revenues but to improve the services and environment for citizens. Over the past few years our downtown garbage cans are overflowing by

Monday morning. Having trash picked up more than once a week is essential.

He also wants to see the city welcome new businesses by providing a city government that is friendly and treats all business owners equitably. The city council should offer compelling incentives to attract and keep business here. From what many business owners tell us, they face business barriers in Orinda that they do not face in other cities.

The downtown area of Orinda can be refurbished to look more inviting and more attractive. Our city looks like the far flung assortment of storefronts that clearly lack a guiding architectural and planning hand. Residents rarely shop here and our kids have nothing to keep them here. It's a travesty.

The expectations of our elected officials must be much higher. This election is about not having our glass being half empty but having it half full. With Dr. Bob Larsen, our community will have a stronger voice to carry out a progressive agenda.

— Rosarie and Bailey Hartmeyer

**Re-elect Victoria Smith**

In the 15 years that we have lived in Orinda, we've had contact with nearly all members of the city council. Without a doubt, Victoria Smith is one of the most accessible and approachable members and one who has a genuine interest in the concerns and needs of all the residents of our community. She truly listens to her constituents, researches and analyzes every issue that comes before her and her colleagues on the council, asks questions, engages in debate and then votes in the manner she believes is in the best interest of all Orindans.

Victoria has demonstrated her integrity and commitment throughout her first term. We trust her to continue to represent our best interests and that of all residents of our city in all matters that the council is now considering and will do so over the next four years. We urge all Orindans to join us in re-electing Victoria Smith to the city council and keep her working on our behalf.

— Mark & Claire Roberts

**Victoria Smith for Orinda City Council**

I first met Victoria Smith in 2003 while serving as a planning commissioner for the City of Orinda. I remember watching her transform from a newcomer to one the most effective commissioners within just a few meetings. She was always well prepared, reasonable and well spoken.

After serving as a planning commissioner, Victoria was elected to the city council and has served as mayor. If you go to a city council meeting, you will see what I mean about being effective. She does her homework on every item on the agenda and it shows. She makes informed decisions, speaks clearly and is to the point.

As a council member, Victoria had the foresight to spearhead the creation of the Traffic Safety Advisory Committee, of which I am a member. With her guidance, we completed Traffic Calming guidelines for the city last year. With her strong support, we are now working on improving pedestrian and bike access in Orinda, with a focus on better walking paths to schools and the downtown area.

Please vote to keep Victoria Smith on the Orinda City Council.

— Tom MacKinnon

**Smith a Leader**

Orinda has many qualities of which we can be proud: our schools, our climate, the beauty of our surroundings.

We can also look to our leaders. One

of them, Victoria Smith, has served our community with particular distinction: as a planning commissioner, member of the city council and mayor. She has been a key figure in dealing effectively with the major issues facing our city.

Victoria is now up for re-election as a member of the city council. Those who believe in good government should support her with great enthusiasm.

In these troubled times we need representatives who understand the issues and who will exercise fiscal responsibility in dealing with them. We urge our citizens to vote for Victoria Smith for re-election to the Orinda City Council.

— Bea and Dick Heggie

**Need Smith's Leadership**

I would like to encourage all my friends and neighbors in Orinda to re-elect Victoria Smith to the city council. We need Victoria Smith's continued leadership. We need a city council person who understands critical infrastructure needs and is willing to work for solutions. Victoria Smith understands that infrastructure has a profound effect on our local economy and the people who live in Orinda. Among Victoria's many accomplishments are the repaving of Moraga Way and the passing of Measure E, the parcel tax that provides the extra hours so that our library stays open 60 hours a week. She created the Traffic Safety Advisory Commission to help neighborhoods manage traffic and has served for many years as a Parent's Club volunteer with our schools.

Please join me in voting for Orinda's future. Vote for Victoria Smith.

— Pam Pulley

**Lots of Common Sense**

I had the good fortune to spend two years on the Orinda City Council with Victoria Smith and have closely followed her performance since then. Victoria gets top marks for her performance, especially this year when she has been mayor. In fact, I don't think very many have done as good a job as she has done serving the people of Orinda.

Victoria is both hard working and intelligent. She always does her homework and asks good questions. She approaches issues with lots of common sense and savvy. She uses her good judgment to make excellent decisions and always articulates her reasons in a clear and concise manner. Most importantly, Victoria's only agenda is doing what is right for Orinda and its citizens.

I know Victoria will continue to be an excellent council member and urge Orindans to vote for her on November 4th.

— Bill Judge

**Smith Hard Working**

Victoria Robinson Smith is running for re-election to Orinda's City Council. She has been a fine and conscientious member of the council, and a citizen of Orinda for long time. It is important to the City of Orinda that we keep in office such a hard working, knowledgeable and productive council member, who is now experienced as well. She has shown an availability to downtown businesses and that has been helpful. I have owned the Orinda Book Store for over 32 years and have known the benefit to the retail sector of her awareness and interest since she has been in office. I urge you to keep her there!

— Janet Boreta

**Smith and Glazer are Keepers for Orinda City Council**

We have had the opportunity to see both Victoria Smith (Orinda Mayor) and Steve Glazer (Orinda City Councilmember and

[SEE LETTERS 3 page 26]

## LETTERS TO THE EDITOR

## ◆ LETTERS 3 from page 25

ex-mayor) in action, and we'd like to encourage our fellow Orinda residents to re-elect them for Orinda City Council.

After seeing the types of issues that they address, from city-wide projects and improvements to neighborhood planning issues, we realize that they have faced two classic problems: balancing interests that are sometimes conflicting and doing so much with so little. Both Victoria Smith and Steve Glazer have volunteered countless amounts of time and expertise, have done an outstanding job of improving our city, and have handled these tough problems with diplomacy, integrity, and always the best interests of our special city, Orinda, in mind and at heart.

Please join us in voting to re-elect Victoria Smith and Steve Glazer for Orinda City Council on November 4th.

— Allison and John Banisadr

**Basic Traits a Plus**

We support Mayor Victoria Smith for her basic traits: integrity, intelligence, common sense, commitment to and understanding of Orinda, and a strong sense of fair play—qualities that are critical to continued excellent leadership in our community.

— Chris and Anne Marie Kniel

**Paving Project**

Please join me in voting for Victoria Smith for re-election to the Orinda City Council. I have known Victoria for over ten years, both professionally and on a personal level. In whatever roles and responsibilities Victoria takes on, her approach is hard-working, level-headed, practical, and efficient. She has brought all of these talents and more to her seat on the city council. One recent example of Victoria's excellent work that benefited all of us is the repaving of Moraga Road. Even though I live on the other side of town, I was dreading that project. With the brilliant planning of Victoria and the others who masterminded the timing and other crucial aspects of the project, I barely had time to become irritated with the dust and traffic delays when the repaving was finished. Let's enjoy at least four more years of this type of contribution to our community by re-electing Victoria Smith.

— Dana Dumas Sankary

**Safeway Store**

In Dvora Citron's letter supporting Steve Glazer's bid for re-election, she praises Glazer for interceding on behalf of Safeway executives who "had received a less than open arms reception" from the city to their plans for remodeling the company's Orinda store.

Bureaucrats and civil servants can sometimes be unnecessarily eager in their attempts to enforce municipal rules and regulations, and there's no reason to believe that ours are any better or worse in that respect than any other city's. However, those rules and regulations were put in place to

protect the interests of all Orindans, not just those of us (myself included) who'd rather not have to drive to Lafayette or Moraga for our arugula. Accordingly, it would be nice to know which rules needed to be bent and which corners had to be cut to pave the way for Safeway to remodel their Orinda store the way they wanted to.

— Seth Knoepler

**Vision for Orinda Clear**

Victoria Smith gets it! Her vision for Orinda is crystal clear — safe roads. She has worked tirelessly to improve the city's roads by being on the Campaign Committee for Measure Q and co-chair for Measure E to obtain funds to repave the city's failed roads. The repavement of Moraga Way happened during her watch.

I've known Victoria and her husband, Wick, and her two sons, Will and Daniel, for the last eleven years. I've known her as a leader in the Cub Scouts and Boy Scouts. She has also been a leader in the Parent's Clubs in Sleepy Hollow, Wagner Ranch, OIS and Miramonte. Whether it's as a parent, planning commissioner or city councilmember, Victoria understands the needs of our families and our community. We need someone in the city council who understands the needs of our community and can find a consensus to tough problems. Victoria Smith's tenure as a city councilmember has been about bringing diverse groups together to find workable solutions! We have a long way to go to fix our roads, and we need to trust people like Victoria Smith to work with different groups and achieve a solution. You can trust Victoria. Vote for Victoria Smith for City Council of Orinda.

— Carlos Baltodano

**Glazer Gets Things Done**

We are happily endorsing Steve Glazer in his campaign for re-election to the city council. We appreciate his earnest and hardworking approach to the job, and we are gratified by changes we have seen in the Orinda city government during his first term.

Steve has been a driving force in involving more citizens in the key issues facing our the city government. Two years ago there were only around 35 residents on city committees and commission. Now, over 70 citizens are involved in committees dealing with the budget, planning reform, revenue enhancement, audit and infrastructure oversight.

He has led the effort on the council to institute objective criteria for funding road repairs. We all know there are not enough funds to fix our roads, but at least the money we do have is going toward the main roads. We certainly appreciate having Moraga Way, Glorietta, Camino Pablo, and parts of Lombardy repaired. Also, the budget has been squeezed and a lot more money is now being spent on roads than prior to his service on the council.

We so much appreciated his leadership

in the successful effort to keep our library open longer each week. Our community spent millions to build this new and beautiful building. It would have been a huge disappointment if the hours of operation had been cut down to just 35 hours a week. In addition, he led the community effort to get Safeway to upgrade and remodel their store.

Finally, Steve campaigned four years ago for reforms to the planning and design review process. The council has acted to make the process fairer and more timely, and they are continuing to work on additional improvements.

We have a great city but we like the many efforts by Steve and the council to not rest in working to make things even better. We urge a vote for Steve Glazer for council.

— Jim and Carol Brovelli

**Orinda Needs Steve Glazer**

We need Steve Glazer on the Orinda City Council. As the neighborhood association representative in our community for many years, I worked very closely with Mr. Glazer on several long term issues regarding EBMUD's proposed expansion of the Orinda Filter Plant. Mr. Glazer rallied against EBMUD expansion with strength and intelligence. He negotiated effectively and represented the interests of our neighborhood for the benefit of all Orindans. We worked closely for more than two years on this issue to a satisfactory resolution.

Mr. Glazer operates calmly, consistently and with the highest integrity even when attacked by individuals that seek to further their own interests. He has many accomplishments during his term: reforming the planning & design review process; furthering retail interest in Orinda; effectively managing our limited funds for road repair; adding much needed transparency in our small town government and so much more. Mr. Glazer has proven himself to be an honest, balanced and intelligent representative for Orinda. I whole heartedly support his re-election and hope you will vote with me for Steve Glazer in November.

— Brandt Williams

**Glazer Hard Working**

I have known Steve Glazer for over 20 years, and he is a tremendously dedicated, hard-working, civic-minded person. He has brought a fresh perspective to the city council and has accomplished much to improve the quality of life in Orinda.

I worked closely with him to improve our wonderful library. He is a leader in our community efforts to support our schools. His service on the fire committee helped bring paramedics to our fire stations. He has urged me and my friends to be better prepared in a disaster and through the Orinda Association has promoted the sale of emergency supplies to me and my neighbors.

Steve takes this volunteer council position very seriously but is the first to say he doesn't have all the answers. When I have

raised concerns, he shares his knowledge and then usually follows up with "why don't you get involved and help your city." I don't always have the time, but I certainly appreciate that he does. I enthusiastically urge Steve Glazer's re-election to the city council.

— Susie Epstein

**Impressed with Smith**

I am continually impressed with Victoria Smith and her pragmatic views on the important issues that face Orinda. As city councilwoman then mayor, she has dedicated her energy towards the important challenge of improving Orinda's roads. During her tenure as mayor, Orinda Way was repaved, and the project was done on time and under budget. Additionally, she has helped to open the lines of communication between the city and the town citizens by arranging to have council members and city representatives attend the Farmers' Market each week. From procuring donations for a police dog that is used both to track robbers and to locate our older citizens suffering from dementia who have wandered off to supporting a traffic safety advisory committee, every single decision she has made has been with careful analysis of the benefits — and costs — to Orinda citizens. Her accomplishments speak for themselves — Victoria Smith is an asset that Orinda cannot afford to lose.

— Charlene Guidry

**Vote for Smith**

We support Victoria Smith for re-election to the Orinda City Council because of her informed, thoughtful, and civil governing style. Her talents and experience are particularly needed to help solve a number of pressing issues, including street infrastructure and fire safety. We urge Orindans to vote to retain Victoria on November 4.

— Wayne and Jo Alice Canterbury

**Support Victoria Smith**

We are writing to urge other Orinda voters to join us in supporting the re-election of Mayor Victoria Smith to the city council. She has been a tireless advocate of public safety, including disaster preparedness, Safe Routes to School, and over-all traffic safety, and has worked diligently to find a responsible means of repairing our roads. She has also been involved in the Chamber of Commerce "Shop Orinda" program and efforts to revitalize our business areas. Her recent work on the Pulte and former library developments will help our city meet state requirements for affordable housing, prevent our loss of Measure C funding, and, hopefully, make it possible for people who work in Orinda to live in Orinda.

Victoria Smith has served the citizens of Orinda well on both the planning commission and the city council. She deserves our support. We need her energy and creativity on our city council. Let's re-elect Victoria Smith to the Orinda City Council!

— Ellen and Joffa Dale

# VOTE! November 4